



# Notice d'utilisation du générateur de vide GEN21-DP101-M

## Gebrauchsanweisung des Vakuumerzeuger GEN21-DP101-M

### Operating instructions for vacuum generator GEN21-DP101-M



Schéma pneumatique | Pneumatikdiagramm | Pneumatic diagram

Schéma électrovanne | Magnetventil-diagramm | Solenoid valve diagram

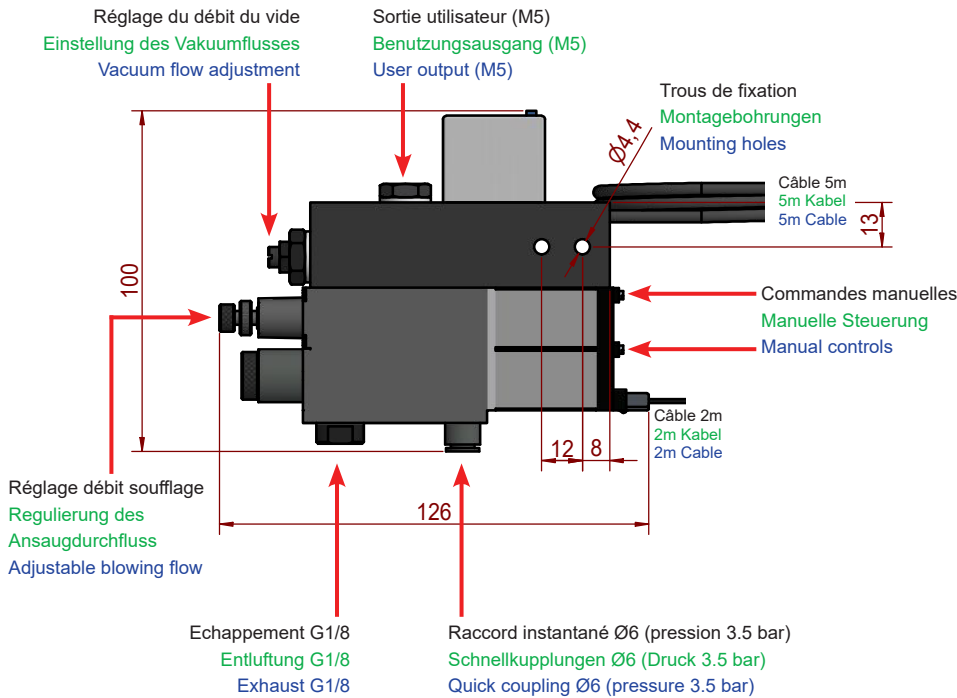
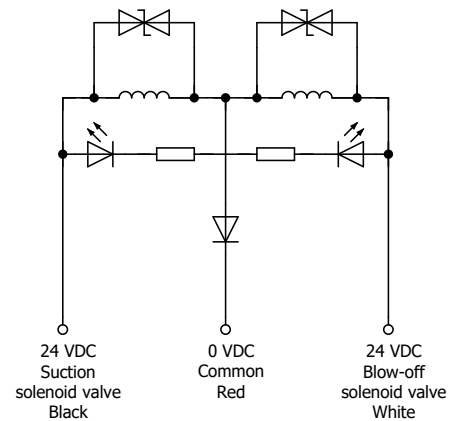
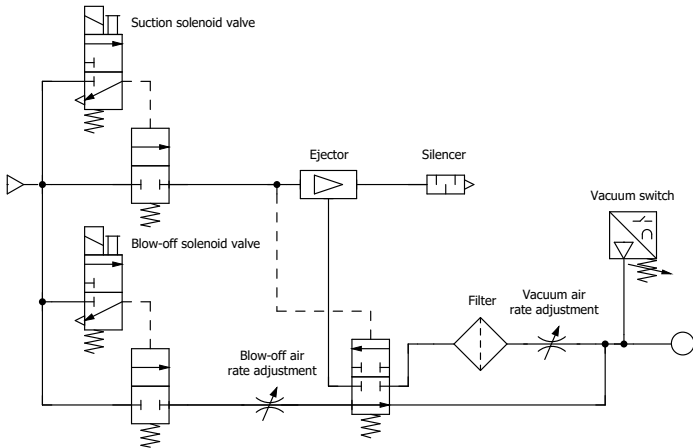

Capteur de pression numérique | Digitaler Drucksensor | Digital pressure sensor

#### Dual display Current value & Threshold value

Equipped with a 30 mm square compact-sized dual display. The current value and the threshold value can be checked at the same time, so the threshold value can be set and checked smoothly without switching to another screen mode. ON / OFF operations still continue while the threshold values are being set, so setting to the same sensitivity as dial control-type sensors is possible. Key lock function is equipped as well.

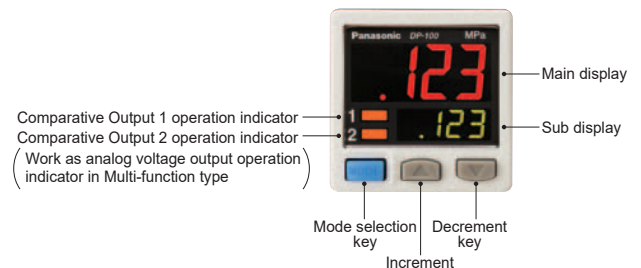

#### Readable digital display

Alphanumeric indication in 12 segments is used. This improved visual checking.

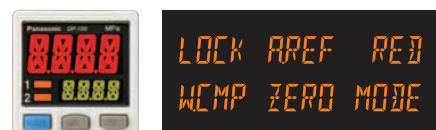

### Possible to switch over analog output and external input

Multi-function type that enables the selection of analog output (voltage / current) or external input (auto-reference / remote zero-adjustment) is available.

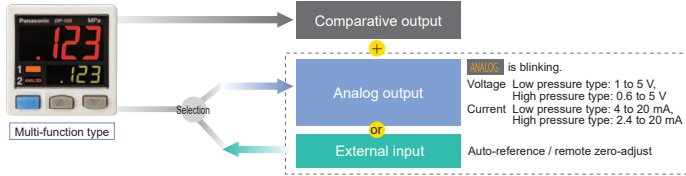

### 3-color display (Red, Green, Orange)

The main display changes color in line with changes in the status of output ON / OFF operation, and it also changes color while setting is in progress. The sensor status can therefore be understood easily and operating errors can be reduced.

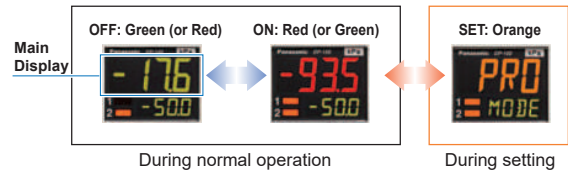

### Equipped with auto-reference / remote zero-adjustment functions, More precise pressure management is achieved with a minimum of effort

If the reference pressure of the device changes, two functions are selectable. One is auto-reference function, which partially shift the comparative output judgment level by the amount that the reference pressure shifts. The other is remote zero-adjustment function, which can reset the display value to zero via external input. These functions are ideal for places where the reference pressure fluctuates wildly, or where fine settings are required.

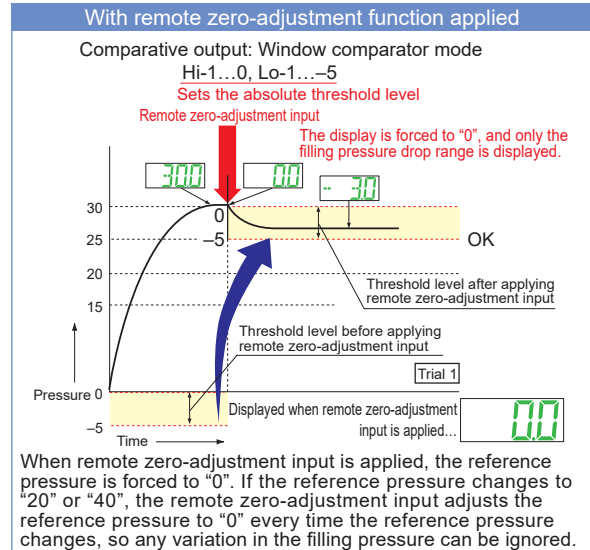
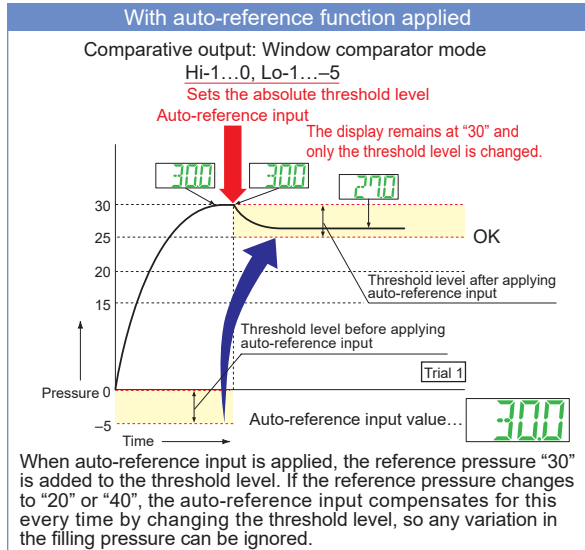

### Sub display can be customized

The sub display can be set to indicate any other desired values or letters apart from the threshold value. This eliminates the need for tasks such as affixing a label to the device to indicate the normal pressure value.



### Setting details can be recognized at a glance

The DP-100 setting details appear in the digital display. Because the settings are in numeric form that can be easily understood, it is useful such as when receiving technical support by telephone. eliminates the need for tasks such as affixing a label to the device to indicate the normal pressure value.

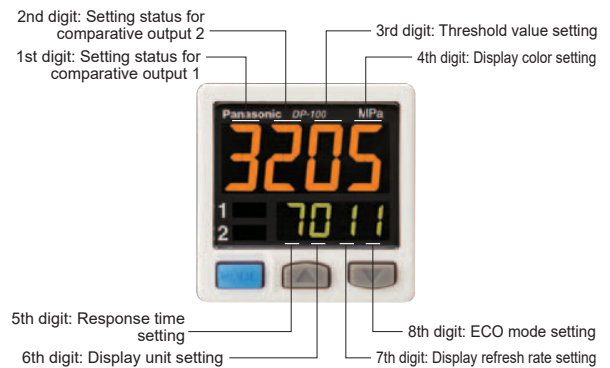

### Peak hold and Bottom hold functions

The peak values and bottom values for fluctuating pressures can be displayed using the dual display.



### Energy-saving design! Equipped with an ECO mode

This mode lowers the display luminance to cut power consumption by approximately 30%. The displays can also be turned off completely to achieve a power saving of approximately 40%.



Current consumption for 24 V power supply: **35 mA or less** (Normal), **25 mA or less** (ECO-STD), **20 mA or less** (ECO-FULL)

## SPECIFICATIONS

Model	DP-101-M-P (Standard)	DP-101A-M-P (Multi-fonction)
Type of pressure	Gauge pressure	
Rated pressure range	-100,0 to + 100,0 kPa	
Set pressure range	-101.0 to + 101.0 kPa - 1.030 to + 1.030 kgf/cm <sup>2</sup> - 1.010 to +1.010 bar - 14.65 to + 14.65 psi - 756 to + 756 mmHg -29.8 to 29.8 inHg	
Pressure withstandability	500 kPa	
Applicable fluid	Air, non corrosive gas	
Selectable unit	kPa, kgf/cm <sup>2</sup> , bar, psi, mmHg, inHg	
Supply voltage	12 to 24 V DC $\pm$ 10 % Ripple P-P 10 % or less	
Power consumption	Normal operation: 720 mW or less (Current consumption 30 mA or less at 24 V supply voltage) ECO mode: 480 mW or less at STD (Current consumption 20 mA or less at 24 V supply voltage) 360 mW or less at FULL (Current consumption 15 mA or less at 24 V supply voltage)	
Comparative output (Comparative output 1, (Comparative output 2 (Note 1))	PNP output type PNP open collector transistor - Maximum source current 100 mA - Applied voltage : 30 V DC or less (between comparative output and +V) - Residual voltage : 2 V or less (at 100 mA source current)	
Output operation	Selectable NO or NC by key operation	
Output modes	EASY mode / Hysteresis mode / Window comparator mode	
Hysteresis	Minimum 1 digit (variable) (however, 2 digits when using psi unit)	
Repeatability	$\pm$ 0.1 % F.S. (within $\pm$ 2 digits)	
Response time	2.5 ms, 5 ms, 10 ms, 25 ms, 50 ms, 100 ms, 250 ms, 500 ms, 1,000 ms, 5,000 ms, selectable by key operation	
Short circuit protection	Incorporated	
External input (Note 2) Auto reference function / Remote zero-adjustment function	_____	ON voltage: 0.4 V DC or less OFF voltage: 5 to 30 V DC, or open Input impedance: 10 k $\Omega$ approx. Input time: 1 ms or more
Analog voltage output (Note 2)	_____	Output voltage: 1 to 5 V DC Zero point: within 3 V $\pm$ 5 % F.S. Span: within 4 V $\pm$ 5 % F.S. Linearity: within $\pm$ 1 % F.S. Output impedance: 1 k $\Omega$ approx.
Analog current output (Note 2)	_____	Output current: 4 to 20 mA Zero point: 12 mA $\pm$ 5 % F.S. Span: 16 mA $\pm$ 5 % F.S. Linearity: within $\pm$ 1 % F.S. Load resistance: 250 $\Omega$ (max.)
Indicator	Orange LED Comparative output 1 operation indicator: comparative output 2 operation indicator, Lights up when each comparative output is ON	Orange LED Comparative output 1 operation indicator: Lights up when comparative output is ON, Analog voltage output operation indicator: Lights up when setting
Environmental resistance	Protection	IP40 (IEC)
	Ambient temperature	- 10 to + 50°C (No dew condensation allowed, Storage : - 10 to + 60°C)
	Ambient humidity	35 to 85 % RH, Storage : 35 to 85 % RH
	Voltage withstandability	1000 V AC for one min. between all supply terminals connected together an enclosure
	Insulation resistance	50 M $\Omega$ or more with 500 V DC megger between all supply terminals connected together an enclosure
	Vibration resistance	10 to 500 Hz frequency, amplitude 0,75 mm or maximum acceleration 49 m/s <sup>2</sup> , in X, Y and Z directions for two hours each
	Shock resistance	10 to 500 Hz frequency, 3 mm in amplitude or maximum acceleration 196 m/s <sup>2</sup> , in X, Y and Z directions for two hours each (when panel is mounted: 10 to 150 Hz frequency, 0.75 mm amplitude or maximum acceleration 49 m/s <sup>2</sup> , in X, Y and Z directions for two hours each)
Pollution degree	2	
Overvoltage category	I	
Temperature characteristics	Within $\pm$ 0.5 % F.S. (at +20 °C)	
Grounding method	Floating	
Material	Enclosure: PBT (glass fiber reinforced), LCD display: Acrylic, Pressure port: Stainless steel (SUS303) Mounting threaded part: Brass (nickel plated), Switch part: Silicone rubber	
Weight	30 g approx.	

Notes :

1) Only standard type is equipped with comparative output 2.

2) Cannot be used at the same time.

High-function type

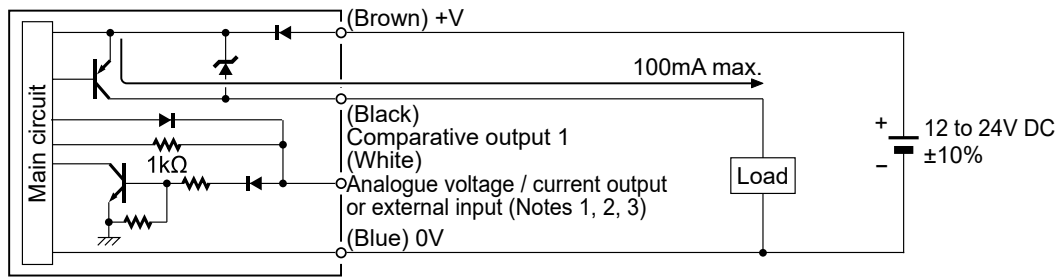

- Notes: 1) When the analogue current is output, the output load resistance should be 250Ω max.
- 2) Take care that when the analogue current is output, 5V or more voltage generates.
- 3) When using the analogue voltage output, be careful to the input impedance of the connected device. Furthermore, note that if the cable is extended, the cable resistance will cause the voltage to drop.

THREE OUTPUT MODES

Equipped with three output modes for use in a wide range of applications

① EASY mode

This mode is used for comparative output ON / OFF control.

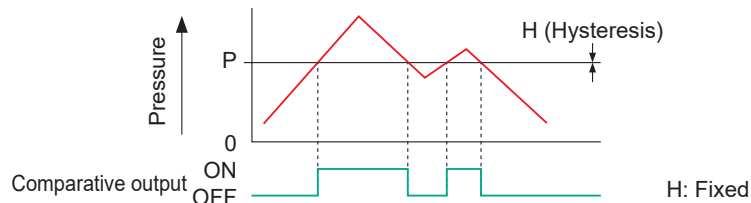

- Notes: 1) Hysteresis can be fixed to one of eight different levels.
- 2) "P-1" appears in the sub display for comparative output 1, and "P-2" appears for comparative output 2.

② Hysteresis mode

This mode is used for setting comparative output hysteresis to the desired level and for carrying out ON / OFF control.

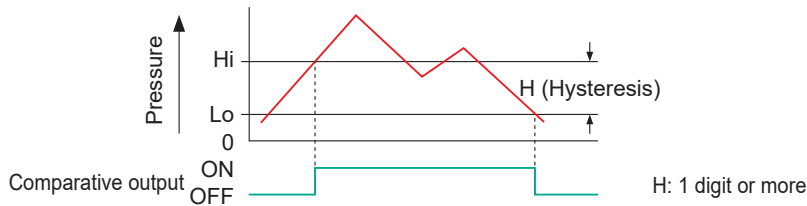

- Note: "Hi-1" or "Lo-1" appears in the sub display for comparative output 1, and "Hi-2" or "Lo-2" appears for comparative output 2.

③ Window comparator mode

This mode is used for setting comparative output ON and OFF at pressures within the setting range.

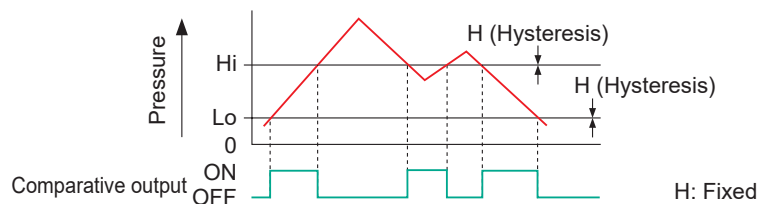

- Notes: 1) Hysteresis can be fixed to one of eight different levels.
- 2) "Hi-1" or "Lo-1" appears in the sub display for comparative output 1, and "Hi-2" or "Lo-2" appears for comparative output 2.

## RUN MODE

### Setting the threshold value

- Refer to <Comparative output 1 / 2 output mode setting>, <Analogue voltage / current output / external input selection> in "MENU SETTING MODE" for setting conditions.
- The Sub display conducts the threshold value. Main display does not changed.

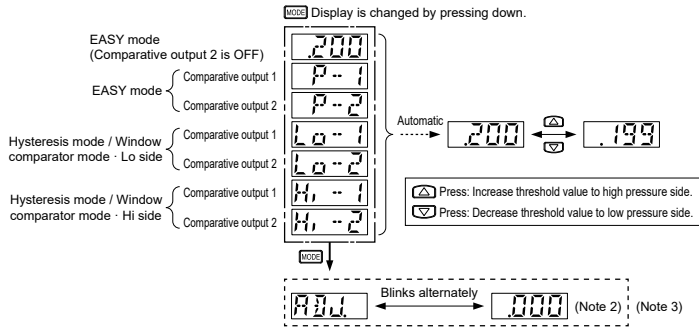

- Notes: 1) If the set pressure range is exceeded, "UP" (exceeds the upper limit) or "DOWN" (exceeds the lower limit) will appear on the sub display. "UP" will also appear if the Hi side threshold value exceeds the Lo side threshold value when setting the "hysteresis mode / window comparator mode" threshold value.
- 2) Auto-reference value and remote zero-adjustment value are displayed.
- 3) In the dash line box is not displaying when not setting "REF" or "ZERO" in external input switch. For the setting method, refer to <Analogue voltage / current output / external input selection> in "MENU SETTING MODE."

### Zero-adjustment function

- The zero-adjustment function forcibly sets the pressure value to "zero" when the pressure port is opened.



### Key lock function

- The key lock function prevents key operations so that the conditions set in each setting mode are not inadvertently changed.

#### <Key lock set>

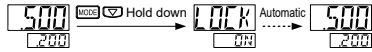

#### <Key lock released>

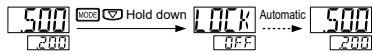

### Peak / bottom hold function

- The peak / bottom hold functions display the peak value and bottom value of the fluctuating pressure.
- The peak value is displayed on the main display and the bottom value is displayed on the sub-display.
- The higher vacuum side indicates the peak value, while the lower vacuum side indicates the bottom value.

#### <Peak / bottom hold set>



#### <Peak / bottom hold released>



## SETTING ITEM

Setting item	Factory setting	Description
Comparative output 1 output mode setting	EASY	Sets the output operation of comparative output 1.
Comparative output 2 output mode setting (Standard type only)	OFF	Sets the output operation of comparative output 2.
Analogue voltage / current output / external input selection (High-function type only)	Vout	Selects analogue voltage / current output, auto-reference input, or remote zero-adjustment input.
N.O. / N.C. selection	Nc (Low pressure type) No (High pressure type)	Normal open (N.O.) or normal close (N.C.) can be selected.
Response time setting	25	Sets the response time. The response time can be selected from 2.5ms, 5ms, 10ms, 25ms, 50ms, 100ms, 250ms, 500ms, 1,000ms or 5,000ms.
Displayed color of the main display selection	R-ON	Displayed color of the main indicator can be changed.
Unit selection	KPa (Low pressure type) MPa (High pressure type)	Pressure unit can be changed.

## MENU SETTING MODE

- The mode will change to RUN mode when the mode selection key is held down during this setting process. In doing so, changed items before holding down the mode selection key have been set.

RUN mode

MODE Press for 2 sec.

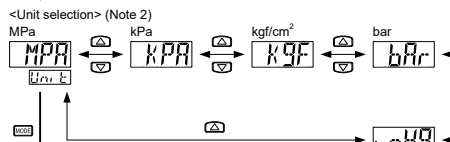
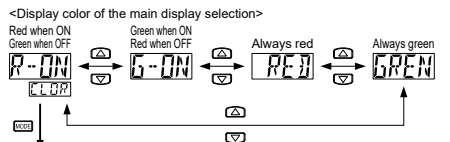
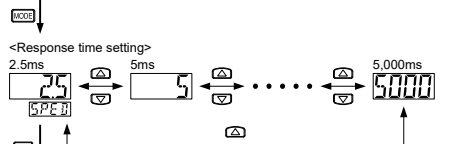
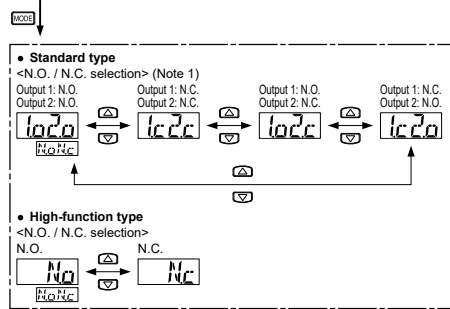
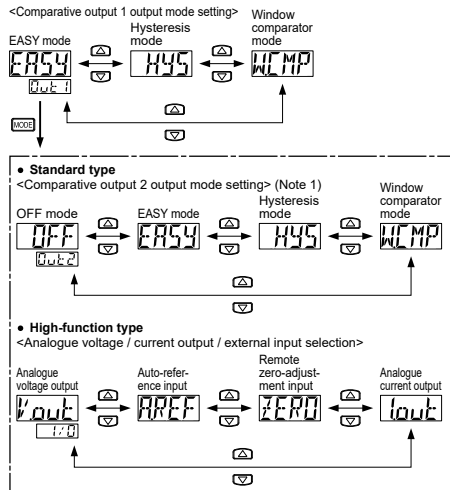

RUN mode

- Notes: 1) If the comparative output 2 output mode setting is set to "OFF", the display of N.O. / N.C. selection is the same as the high-function type.
- 2) In case Japanese, only "MPa" or "kPa" can be set. In the case of a low pressure type, the unit switch setting item is not displayed.
- 3) This is not displayed on the high pressure type.

## ERROR INDICATION

Error message	Cause	Corrective action
E-1	The load is short-circuited causing an overcurrent to flow.	Turn the power OFF and check the load.
E-3	Pressure is applied during zero-point adjustment.	Applied pressure at the pressure port should be brought to atmospheric pressure and zero-point adjustment should be done again.
E-4	External input is carried out outside the rated pressure range.	Applied pressure range should be brought within the rated pressure range.
E-5	Communication error (Disconnection, faulty connection, etc.)	Check the wiring when using the copy function.
E-6	Communication error (Incorrect model.)	Make sure that the system is configured of the same models when using the copy function.
10 10	The applied pressure exceeds the upper limit of the display pressure range.	Applied pressure range should be brought within the rated pressure range.
10 10	The applied pressure exceeds the lower limit of the display pressure range.	

## PRO MODE

- The mode will change to RUN mode when the mode selection key is held down during this setting process. However, changed items before holding down the mode selection key have been set.

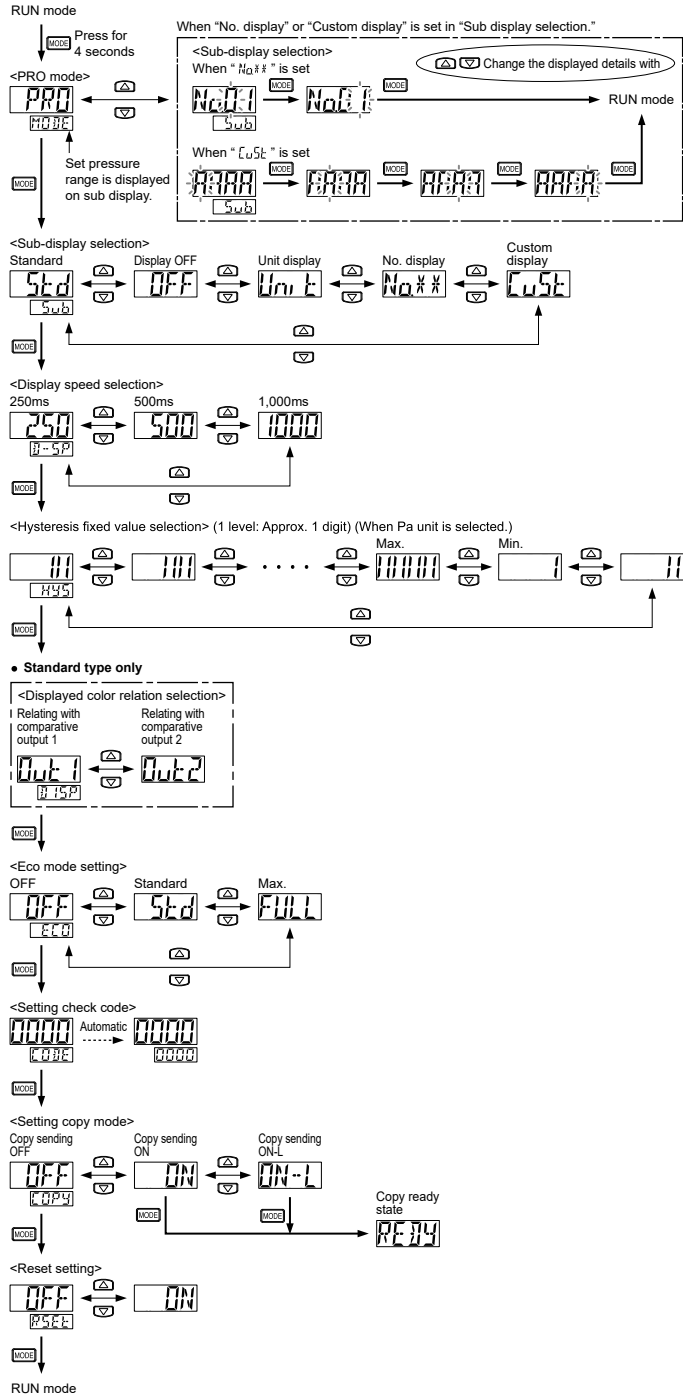

## TABLE OF CODES

Code	1st digit	2nd digit			3rd digit	4th digit	
		Comparative output 1 output mode	NO / NC switching	Comparative output 2 output mode		NO / NC switching	Multi-function type
0	EASY	NO	OFF	OFF	P-1, Lo-1	Red when ON	Standard output 1
1		NC	EASY	NO			Auto-reference
2	Hysteresis	NO		NC	NC	P-2, Lo-2	Green when ON
3		NC	NO	NO	Analog current output		
4	Window comparator	NO	Hysteresis	NC	ADJ.	Always red	Comparative output 1
5		NC		NO			NO
6	—	—	Window comparator	NC	—	Always green	Comparative output 1
7	—	—		—	—		Comparative output 2

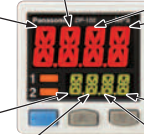

Code	5th digit	6th digit	7th digit	8th digit
0	Response time	Unit switching	Display refresh rate	ECO mode
1	2.5 ms	MPa	250 ms	OFF
2	5 ms	kPa	500 ms	STD
3	10 ms	kgf/cm <sup>2</sup>	1,000 ms	FULL
4	25 ms	bar	—	—
5	50 ms	psi	—	—
6	100 ms	mmHg	—	—
7	250 ms	inchHg	—	—
8	500 ms	—	—	—
9	1,000 ms	—	—	—
	5,000 ms	—	—	—

## SETTING ITEM

Setting item	Factory setting	Description
Sub-display selection	Std	Changes the indication of the sub-display. " OFF " : Displays nothing. " Unit " : Presently selected pressure unit is displayed. " No. " : Desired No. can be shown. " CuSt " : Desired numbers, alphabets (some of them cannot be displayed) and signs can be shown.
Display speed selection	250	Changes the speed of the displayed pressure value on the main display.
Hysteresis fixed value selection	00	Sets hysteresis of the EASY mode and the window comparator mode. (8 steps)
Displayed color relation selection (Standard type only)	Out 1	The setting contents set at the displayed color setting in Menu setting mode can be related with either comparative output 1 or comparative output 2.
Eco mode setting	OFF	Current consumption can be lowered. " OFF " : Normal operation (ECO mode is off.) " Std " : If any key operation is not carried out for approx. 5 sec. in RUN mode, the display becomes dark. " FULL " : If any key operation is not carried out for approx. 5 sec. in RUN mode, the display is turned off. Press any key to temporarily show the normal indication.
Setting check code	0000	Current setting contents can be checked. For codes, refer to "Code table".
Setting copy mode	OFF	The setting of the master side sensor can be copied to the slave side sensors. For details, refer to "SETTING COPY FUNCTION." " ON " : The setting contents are copied. " ON-L " : The setting contents are copied, and the slave side sensor goes into key-lock state.
Reset setting	OFF	Returns to default settings (factory settings). By pressing down mode key when " ON " mode, becomes default settings (factory settings).