

DYNAMCO

PRECISION PNEUMATIC PRODUCTS

Miniature High Speed Air Valves

AND ACCESSORIES



Quality Pneumatic Products for over 40 years





TABLE OF CONTENTS

DASH 1	1-11	DASH 3 PILOT ASSISTED SOLENOID	28-38
Cutaway Drawing.....	2	Cutaway Drawing.....	28
Color Coding.....	1,2,6	Temperature Range	30
Mounting Styles	3	Materials	30
Electrical Connector Options	4	Pressure Range.....	30
Temperature Range	5	Filtration	30
Electrical Specifications	5	Electrical Connector Options	28, 31
Part Number Selection Guide	6	Part Number Selection Guide	31
Pressure Range.....	6	Flow Curve.....	31
Flow Curves.....	6	Footprint.....	35
Dimensional Drawings	7,9	Baseplates	37
DIN Connector	10	Manifolds	38
Blank Station Cover	10		
Manifolds	8-11	DASH 3 DIRECT OPERATED SOLENOID ..26-27, 32-33, 36-38	
CENTRAL CONNECTORS	12-17	Cutaway Drawing.....	32
Dash 1 Part Number Selection Guide.....	13	Part Number Selection Guide	33
D Sub Male 15-pin Numbering System	14	Filtration	33
Dash 2 & 3 Part Number Selection Guide	15	Materials	33
D-Sub Male 25-pin Numbering System	16	Temperature Range	33
		Footprint.....	35
BLEED FEED	18-19	DIN Connector	36
Applications Examples.....	18	Baseplates	37
Part Number Selection Guide	19	Manifolds	38
		DASH 3 AIR PILOT	34-38
DASH 2 PILOT ASSISTED SOLENOID VALVE	20-27	Part Number Selection Guide	34
Cutaway Drawing.....	20	Filtration	34
Electrical Connector Options	20,23	Materials	34
Temperature Range	22	Temperature Range	34
Materials	22	Footprint.....	35
Pressure Range.....	22	Baseplates	37
Filtration	22	Manifolds	38
Part Number Selection Guide	23	STACKABLE MANIFOLDS	39-43
Flow Curve.....	23	10/32" Description.....	39
Baseplates	26	Mounting Bracket.....	39
Manifolds	27	10/32" Illustrated Part Number List	40
		1/8" Description.....	41
DASH 2 AIR PILOT	24-27	1/8" Drawings.....	42
Cutaway Drawing.....	24	1/8" Part Number List.....	43
Part Number Selection Guide	25		
Filtration	25	SANDWICH REGULATOR	44-45
Materials	25	Specifications.....	44
Temperature Range	25	DIGITAL POSITIONING SYSTEM	46-47
Baseplates	26	DATE CODES	48
Manifolds	27	FITTINGS	Inside Back Cover



While the information in this catalog is believed to be accurate, DYNAMCO does not guarantee satisfactory results from reliance upon this information. Nothing contained herein is to be construed as a warranty or guarantee, express or implied, regarding the performance, fitness, or any other matter with respect to the products. DYNAMCO reserves the right, without notice, to alter or improve the designs or specifications of the products described herein. DYNAMCO is an ISO Certified company. All products are RoHS compliant. Please note, UL Certification excludes Dash-3 Direct Operated Solenoids (DOS), as well as other DYNAMCO products not specific to this catalog.

Dash 1 Valves



D123201 VALVE

Shown with 2458-0 Removable Electronic Connector (Connector sold separately)



FLYING LEADS VALVE

D152604 Shown with 211-1 Fittings (Fittings not included)



D113301 VALVE

Shown with 2270-0 Removable DIN Connector (Connector sold separately)



INTRODUCTION

DYNAMCO'S DASH 1 valve family is based on a direct solenoid poppet that can be either a three way (3/2) or a two way (2/2) valve. The DASH 1 is a precision combination of miniature size, fast response, high flow, low power, and long life. There are several valve versions in the DASH 1 family. Cataloged models include: ports in body, manifold mount, adapter plate, PC board mount, and 1/8 pipe-stud output.

MINIATURE SIZE

DASH 1 can be mounted on .630 inch (16mm) centers. For dimensions, please see pages 7 and 9-11.

HIGH SPEED

DYNAMCO's DASH 1 will oscillate over 160 cycles per second using conventional electronics. Some customers have utilized enhanced electronics and achieved speeds as high as 500 cycles per second. A DASH 1 valve will shift from a standing start in 3 to 6 milliseconds.

REPEATABILITY

Many applications require very consistent operation. DASH 1 has unmatched repeatability. This consistency continues month after month, year after year over a broad range of temperature and humidity. While this is a difficult parameter to quantify, the best proof lies in the reputation of our products with long term customers.

LOW ELECTRICAL POWER

DASH 1 is offered in three power levels: 0.6 watt, 1.2 watt, and 2.5 watt. Page 8 illustrates a comparison of performance and power requirements. Electrical Specifications are shown on page 5.

COLOR CODING

A color coding system is used to identify a DASH 1 valves orifice size.

- Black: .031 inch (0.8mm) orifice
- Red: .063 inch (1.6mm) orifice
- Silver: .089 inch (2.3mm) orifice

HIGH FLOW

The .031 inch (0.8mm) model has a C_v of .02 and provides air flow of 1.25 cubic feet per minute (35 liters per minute). The .062 inch (1.6mm) orifice has a C_v of .04 and provides air flow of over 3 cubic feet per minute (85 liters per minute). The .089 inch (2.3) orifice has a C_v of .08 and provides air flow of 4.75 cubic feet per minute (134 liters per minute) See flow curves on Page 6.

LONG LIFE

The design life of DYNAMCO's DASH 1 valves is 100 million cycles. When operated within its recommended operating specifications, laboratory tests and field experience have confirmed life well in excess of this.

LED INDICATOR

DASH 1 valves have a standard LED indicator. **Note:** Take care to connect the positive wire (red) to the #1 or + terminal and the negative wire (black) to the #2 or -terminal when attaching the signal wires to the connector. If the polarity is reversed, the valve will work, but the LED will not illuminate. If the LED appears dim, check the voltage level supplied to the solenoid. It is probably below the minimum rated level.

MANUAL OVERRIDE

A manual override is standard on all cataloged DASH 1 valves. When the button is pressed, the armature is mechanically actuated just as if the solenoid is energized. It is non-locking and spring returned.

QUALITY

Quality must be present in both design and manufacturing. Our strict standards ensure the DASH 1 valve is the highest quality design available. **We are an ISO 9001:2008 certified company.**

DYNAMCO manufactures nearly all components for DASH 1 in its own manufacturing facility. Every DASH 1 is given a complete battery of tests at various stages of manufacture. DYNAMCO's care and attention to detail mean you receive a thoroughly proven product when it is finally given the DYNAMCO name and packed for shipment.



Dash 1 Valves

DASH 1 QUALITY DESIGN FEATURES

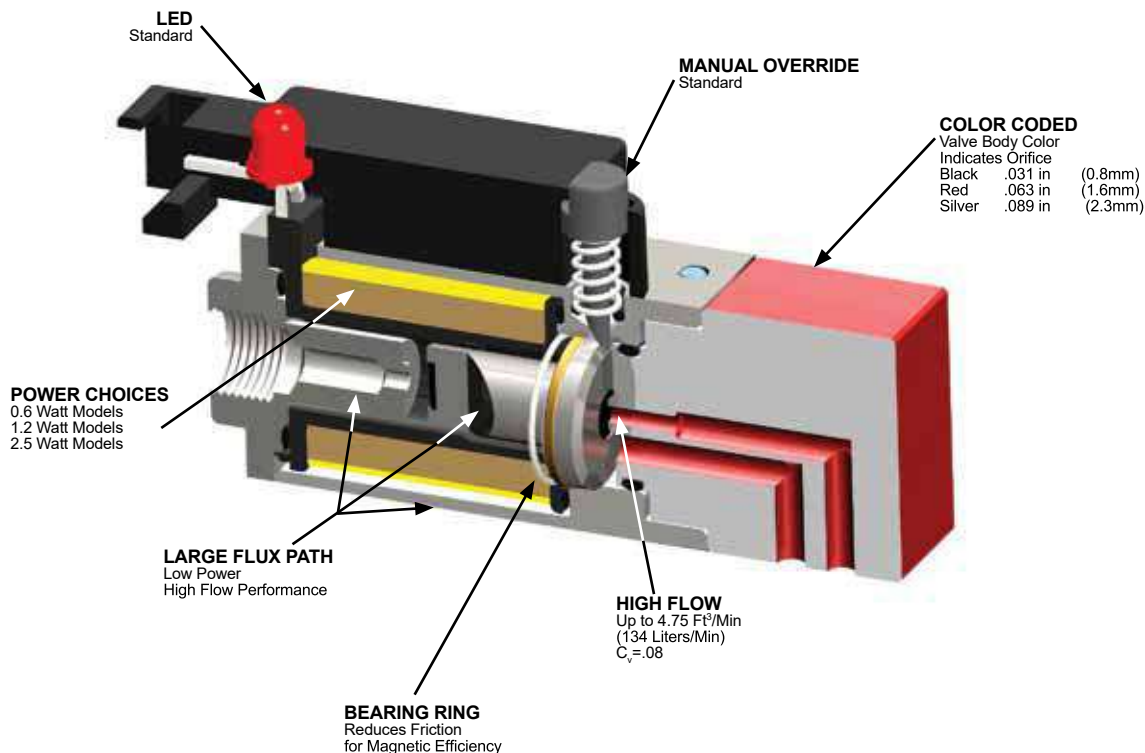

LIFE
100,000,000 Cycles Typical
500,000,000 Cycles Achievable

CONNECTOR
Choice of DIN, Electronic, PC Board, or Flying Leads

REPEATABILITY
Precise Duplication of Response

FAST RESPONSE
Over 160 Cycles/Sec & 3-6 ms Shift Time
500 Hz achievable

VACUUM
Suitable for Vacuum Applications

CONFIGURATIONS
Valves Available as Normally Open
or Normally Closed

MINIATURE SIZE
Allows .630 in (16mm) Valve Spacing

MINIMAL PARTS
For Reliability and Simplicity

MANIFOLDS
Large Choice of Models

PRECISION FIT
For Optimal Speed (response) and Flow

Dash 1 Valves



PORTS-IN-BODY

The DASH 1 Ports-in-Body valve provides inlet, outlet, and exhaust ports suitable for 10-32 or M5 fittings. There are also two sets of holes provided for mounting the valve.
See drawing on page 7.



PORTS-IN-BODY VALVE
D112202 Shown with 211-2 Fitting
(Fittings not included)

MANIFOLD MOUNTING

DASH 1 offers a manifold version which can be mounted as close as .630 inch (16mm) center distance. It features a recessed gasket that will not blow out. The DASH 1 valve can be removed from a manifold by unscrewing the two M3 valve mounting screws.
See drawing on page 9.



MANIFOLD MOUNT VALVE
D123201 Shown

ADAPTER MOUNTING

The adapter mounting is useful when the shortest length DASH 1 needs to be mounted to a flat surface. This feature can also be used to adapt the DASH 1 as the operator for another valve.
See drawing on page 7.



ADAPTER MOUNTING VALVE
D113203 Shown

1/8 PIPE STUD OUTPUT

The DASH 1 valve can be ordered with either a 1/8 NPT or a 1/8 BSPP male stud output. This configuration is ideal for both mounting and making a pneumatic connection to pneumatic cylinders, actuators and to the pilot ports of larger valves.
See drawing on page 7.



1/8 PIPE STUD OUTPUT
D113304 Shown

CONNECTOR OPTIONS

The DASH 1 valve is available with electronic connector, DIN connector, PC Board mounting, or Flying Leads. Flying leads are available in standard lengths of either 16 or 80 inches. For large quantities, we can design a valve with a custom connector or flying leads of a custom length.
More information about connector options can be found on page 1, 4, & 6.

FUTURE BODIES AND SPECIAL BODIES

DYNAMCO's unique body attachment is designed to accommodate new design valve body configurations, and our skilled engineers can work with you to design a custom valve for your unique application.



SOLENOID OPERATOR ONLY
D113200 Shown



Dash 1 Valves

DIN CONNECTOR

We recommend the DIN connector where maximum durability is needed. The terminals on the solenoid operator are also compatible with fast-on type wire terminals. The removable DIN connector must be ordered separately.



REMOVABLE DIN CONNECTOR P/N 2270-0

ELECTRONIC CONNECTOR

Use the electronic connector for low profile compact applications. The positive wire is red and the negative wire is black. The removable electronic connector must be ordered separately.

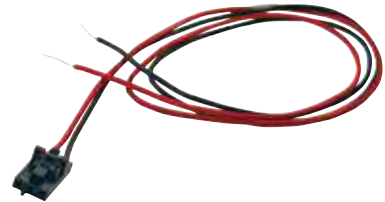

ELECTRONIC CONNECTOR 16 IN (40 cm) P/N 2458-0
80 IN (200 cm) P/N 2458-2

ALTERNATING CURRENT (AC) OPERATION

When AC electrical signals are to be connected to a DASH 1 valve (or DASH 2 or DASH 3 valves using a DASH 1 solenoid operator), use one of DYNAMCO's AC lead wires. DYNAMCO's AC lead wires contain a full wave bridge rectifier and a surge suppressor. This converts the AC to rectified AC with circuit protection which is suitable for use with a DASH 1 DC solenoid operator of the same voltage. See schematic below. Note the AC connections have no polarity. The rectified AC is color coded red for positive and black for negative.

AC LEAD WIRES

For DIN connector applications, attach DYNAMCO's AC Lead Wires to the terminal strip of the electronic controller and splice the other ends to a cord leading to the DIN connector. Fast-on terminals can simply be crimped on the valve end of the AC Lead Wires.



AC LEAD WIRES 16 IN (40 cm) P/N 2588-7
80 IN (200 cm) P/N 2598-7

AC ELECTRONIC CONNECTOR

Electronic connector AC lead wires are supplied complete with electronic connector, circuit module and lead wires. The AC ends should be attached to the terminal strip of the electronic controller and the electronic connector plugged into a DYNAMCO DASH 1 solenoid operator.



AC ELECTRONIC CONNECTOR 16 IN (40 cm) P/N 2587-7
80 IN (200 cm) P/N 2597-7

ALTERNATING CURRENT CIRCUIT MODULE DIAGRAM

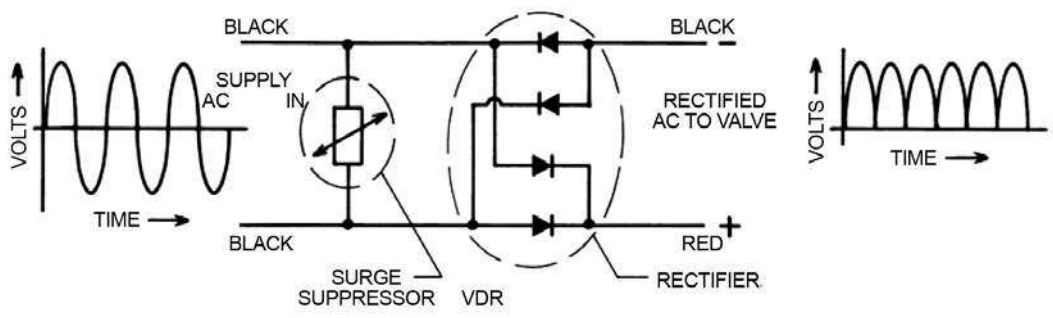

Dash 1 Valves



NORMALLY CLOSED (NORMALLY NOT PASSING)

The DASH 1 valve is most often applied as a normally closed (NC), or normally not passing valve. In this configuration, a pneumatic supply should be connected to port P and the output port A should be connected to the device to be pressurized. The exhaust port R is the port at the end of the solenoid. The valve symbol is shown below.

NORMALLY OPEN (NORMALLY PASSING)

The DASH 1 valve can be used as a normally open (NO) or normally passing valve by connecting the supply air to port R in the end of the solenoid and using port A for the output. The valve symbol is shown below.

VACUUM APPLICATIONS

Certain DASH 1 valves are suitable for use in vacuum applications as shown on page 6. We can also build custom valves for vacuum applications. Please contact our sales department and we will be glad to design and build a valve that meets specific requirements.

PRESSURE RANGE

DASH 1 valves can be operated over the pressure ranges shown on page 6. Note, in order to achieve the highest operating performance, care should be taken to choose the optimum model for the application.

TEMPERATURE RANGE

For DASH 1 Models Below 1 Watt:
0° to 150°F (-18° to 65°C)

For DASH 1 Models Above 1 Watt:
0° to 122°F (-18° to 50°C)

SERVICE, FILTRATION, AND LUBRICATION

DASH 1 valves are designed for service on air and inert gasses. DYNAMCO recommends 40 micron filtration. The DASH 1 valve is a direct acting poppet and is very forgiving of contamination. Lubrication is not required.

MOUNTING

Dash 1 valves can be mounted in any orientation and still achieve excellent performance.

ALTERNATIVE VOLTAGES AND POWER LEVELS

DYNAMCO can supply nearly any DC voltage and lower power levels at reduced operating pressures. If your requirements cannot be met by DYNAMCO's standard DASH 1 valves, contact DYNAMCO or any of our authorized distributors throughout the world.

MATERIALS

Solenoid Housing.... Electroless Nickel or Zinc Plated S.S.
Pole Piece..... Electroless Nickel or Zinc Plated S.S.
ArmatureProprietary
Seals Buna N
Valve Body Anodized Aluminum

NOTE: Other materials available upon request.

ELECTRICAL SPECIFICATIONS			
Voltage (Volts)	Power (Watts)	Resistance (OHMS)	Current (Amps)
5*	0.6	45	.111
5*	1.2	23	.210
5*	2.5	10	.500
12*	0.6	260	.050
12*	1.2	120	.100
12*	2.5	60	.185
24*	0.6	1100	.027
24*	1.2	500	.052
24*	2.5	235	.100
115*	2.5	5500	.021

*The voltage can be AC (50/60 Hz) or DC. For AC operation use AC lead wires (described on page 4) and the proper voltage DC DASH 1 valve. Voltage tolerance is +15% -10% of rated. Solenoids are rated for continuous duty.

DASH 1 VALVE SYMBOLS

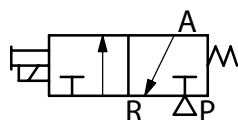

3 WAY (3/2) NC
(normally not passing)

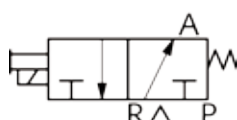

3 WAY (3/2) NO
(normally passing)

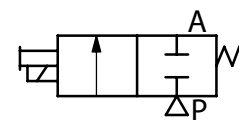

2 WAY (2/2) NC
(normally not passing)



Dash 1 Valves

DASH 1 MODEL NUMBERING SYSTEM

EXAMPLE: **D11 3 3 01**

VALVE TYPE

(see valve characteristics below)
 ...D11 ...D15 ...D1C ...D1J
 ...D12 ...D16 ...D1F ...D1K
 ...D13 ...D1A ...D17 ...D1L
 ...D14 ...D1B ...D18 ...D1M
 ...D1P

VOLTAGE

5 VDC.....1
 12 VDC.....2
 24 VDC.....3
 115 VDC.....5
 5 VDC w/Diode...A
 12 VDC w/Diode...B
 24 VDC w/Diode...C
 See notes 2 and 3

CONNECTOR

ELECTRONIC.....2
 DIN.....3
 PCB.....4
 16" FLYING LEADS.....5
 80" FLYING LEADS.....6

VALVE PORTS AND MOUNTING

SOLENOID OPERATOR ONLY...00
 MANIFOLD MOUNTING.....01
 PORTS IN BODY.....02
 ADAPTER BASE.....03
 1/8 NPT MALE OUTPUT.....04
 1/8 BSPP MALE OUTPUT.....05
 PCB.....06

- NOTES:**
1. Removable connectors and lead wires must be ordered separately. See page 4.
 2. All voltages can be used on either AC or DC electrical service by ordering the proper AC or DC lead wires. See page 4.
 3. 115V only available in 2.5 watt models.
 4. .089 silver series not available in 03 adapter base mounting.

DASH 1 VALVE CHARACTERISTICS

Valve Type	Valve Function	Orifice IN (MM)	Power (Watts)	REM	PRESSURE (PSIG / BARS)																
					7	6	5	4	3	2	1	0	1	2	3	4	5	6	7	8	9
D11	3 WAY (3/2)	.031 (0.8)	0.6	BLACK	[Flow Characteristics]																
D12	3 WAY (3/2)	.062 (1.6)	2.5	RED	[Flow Characteristics]																
D13	3 WAY (3/2)	.062 (1.6)	1.2	RED	[Flow Characteristics]																
D14	3 WAY (3/2)	.031 (0.8)	0.6	BLACK	[Flow Characteristics]																
D15	3 WAY (3/2)	.062 (1.6)	2.5	RED	[Flow Characteristics]																
D16	3 WAY (3/2)	.031 (0.8)	2.5	BLACK	[Flow Characteristics]																
D1A	2 WAY (2/2)	.031 (0.8)	0.6	BLACK	[Flow Characteristics]																
D1B	2 WAY (2/2)	.062 (1.6)	2.5	RED	[Flow Characteristics]																
D1C	2 WAY (2/2)	.062 (1.6)	1.2	RED	[Flow Characteristics]																
D1F	2 WAY (2/2)	.031 (0.8)	2.5	BLACK	[Flow Characteristics]																
D17	3 WAY (3/2)	.031 (0.8)	0.3	BLACK	[Flow Characteristics]																
D18	3 WAY (3/2)	.062 (1.6)	0.6	RED	[Flow Characteristics]																
D19	3 WAY (3/2)	.089 (2.3)	1.2	SILVER	[Flow Characteristics]																
D1N	3 WAY (3/2)	.089 (2.3)	1.2	SILVER	[Flow Characteristics]																
D1G	3 WAY (3/2)	.031 (0.8)	0.3	BLACK	[Flow Characteristics]																
D1H	3 WAY (3/2)	.031 (0.8)	0.3	BLACK	[Flow Characteristics]																
D1J	3 WAY (3/2)	.062 (1.6)	1.2	RED	[Flow Characteristics]																
D1K	3 WAY (3/2)	.062 (1.6)	2.5	RED	[Flow Characteristics]																
D1L	3 WAY (3/2)	.089 (2.3)	2.5	SILVER	[Flow Characteristics]																
D1M	3 WAY (3/2)	.089 (2.3)	2.5	SILVER	[Flow Characteristics]																

0.089 in (2.3) Orifice

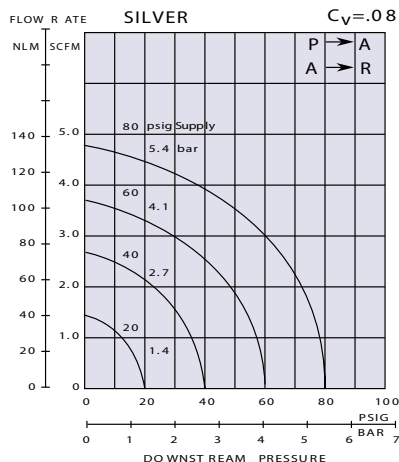

0.062 in (1.6) Orifice

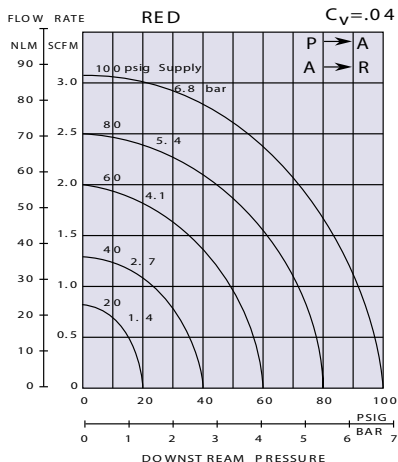

0.031 in (0.8) Orifice

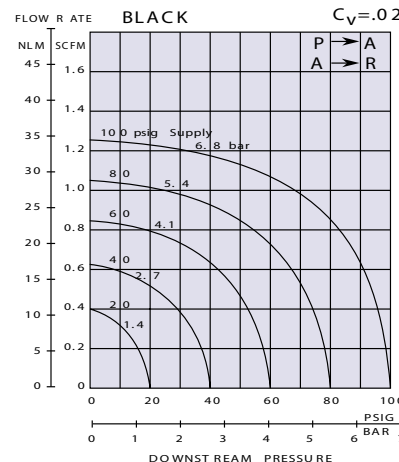

Dash 1 Valves



DASH 1 VALVE BODY PORTS IN BODY

Part Number	Orifice Size
2523-2 Black	.031 (0.8)
2524-2 Red	.063 (1.6)
3079-2 Silver	.089 (2.3)

NOTE: Part number is for body O-ring and Pins.

REMOVABLE ELECTRONIC CONNECTOR PART NUMBER 2458-0, MUST BE ORDERED SEPARATELY.

MOUNTING HOLES 0.125 (3.2mm) DIA THRU 2 PLACES

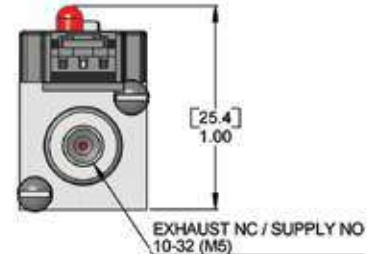
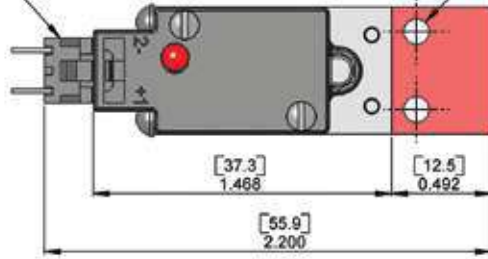

OUTPUT PORT 10-32 (M5)
BODY SHOWN IN STANDARD POSITION BUT CAN BE ROTATED TO ORIENT PORTS AS DESIRED.

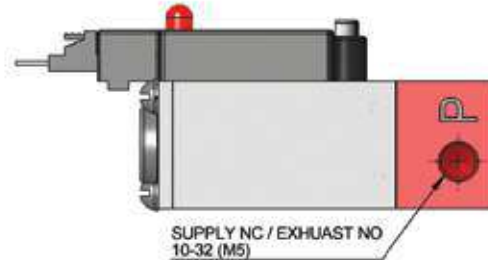

DASH 1 VALVE BODY 1/8 PIPE STUD

Part Number	Orifice Size	Pipe Thread
2523-4 Black	.031 (0.8)	1/8 NPT
2524-4 Red	.063 (1.6)	1/8 NPT
3079-4 Silver	.089 (2.3)	1/8 NPT
2523-5 Black	.031 (0.8)	1/8 BSPP
2524-5 Red	.063 (1.3)	1/8 BSPP
3079-5 Silver	.089 (2.3)	1/8 BSPP

NOTE: Part number is for body O-ring and Pins.

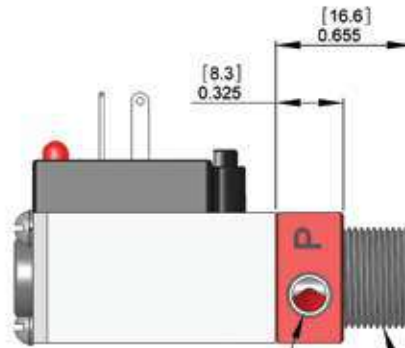

SUPPLY NC / EXHAUST NO 10-32 (M5)
BODY SHOWN IN STANDARD POSITION BUT CAN BE ROTATED TO ORIENT PORTS AS DESIRED.

OUTPUT PORT 1/8" NPT OR 1/8" BSPT (SEE CHART)

DASH 1 VALVE ADAPTER PLATE

Part Number	Orifice Size
2523-3 Black	.031 (0.8)
2524-3 Red	.063 (1.6)

NOTE: Part number is for adapter O-ring, Screws, Gasket and Pins.

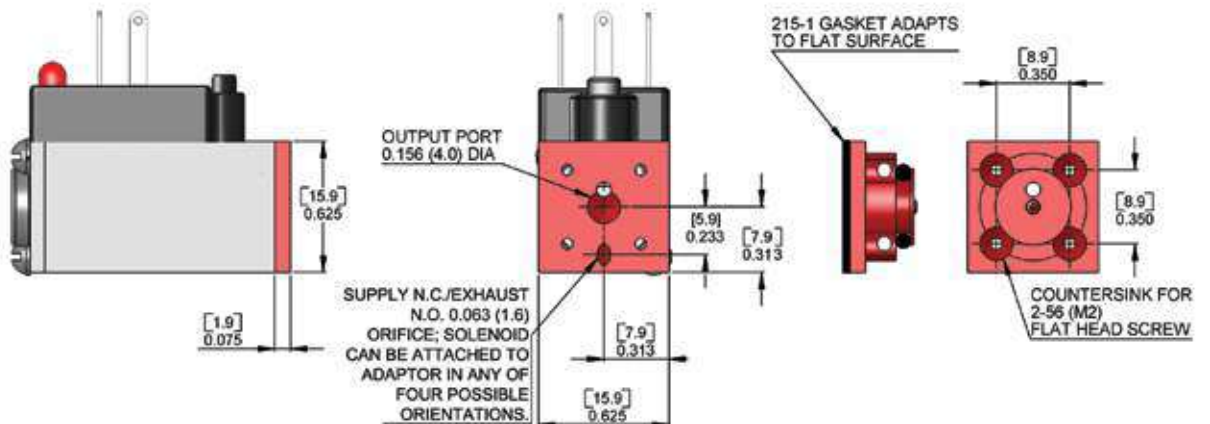



Dash 1 Manifolds

MANIFOLDS

There are four styles of manifolds cataloged in the DASH 1 family. Drawings, model numbers, and dimensions are shown on pages 9 thru 11.

10-32 (M5) SUPPLY MANIFOLD

This manifold is designed for smaller applications up to 6 valves. The supply can be fed from both ends to provide adequate air flow. There is also an auxiliary gallery that can be used to capture the exhaust of the valves by making a tubing connection to the auxiliary gallery. Part numbers and dimensions are shown on page 9.



4 STATION 10-32 [M5] SUPPLY MANIFOLD
Shown with 4 Each D123201 Valves

1/8 NPT OR 1/8 BSPP SUPPLY SINGLE SIDED

This manifold also allows supply from both ends. Part numbers and dimensions are shown on page 10.



4 STATION 1/8 PIPE SUPPLY SINGLE SIDED MANIFOLD
Shown with 4 Each D123301 Valves

1/8 NPT OR 1/8 BSPP SUPPLY DOUBLE SIDED

This manifold is similar to the single sided manifold, but allows valves to be mounted on both sides of the manifold. Part numbers and dimensions are shown on page 11.



8 STATION 1/8 PIPE SUPPLY DOUBLE SIDED MANIFOLD
Shown with 8 Each D123301 Valves

DASH 1 IN-LINE SINGLE MANIFOLD

Dynamco also offers a single, in-line manifold for the DASH 1 product line. This manifold allows users to easily incorporate Dynamco 2-way and 3-way valves into circuits with 1/8" NPT or BSPP connections. In addition to the high speed performance and long life that the DASH 1 delivers, this package also enables easier field maintenance for the end user. Because the Dynamco assembly is a manifold style, the valve can be replaced without having to remove the manifold assembly from the pipe work, simplifying routine maintenance.

The manifold can be used with any DASH 1 Valve configured with manifold mounting. The DASH 1 Valve is mounted in the same manner as with other Dynamco manifolds. The manifold part numbers are as follows:

Part Number	Connection
3081-0	1/8" NPT
3082-0	1/8" BSPP

The 1/8" connections apply to the "P" Port and "A" Port only. For 3-way versions of the DASH 1 valve, the "R" Port will continue to be accessed on the valve, using the 10-32 (M5) connection. However in most applications, the "R" Port is used only for exhaust and will not require piping. Dimensions are shown on page 11.



IN-LINE SINGLE MANIFOLD
Shown with D123301

Dash 1 Manifolds



DASH 1 MANIFOLD MOUNTED VALVE

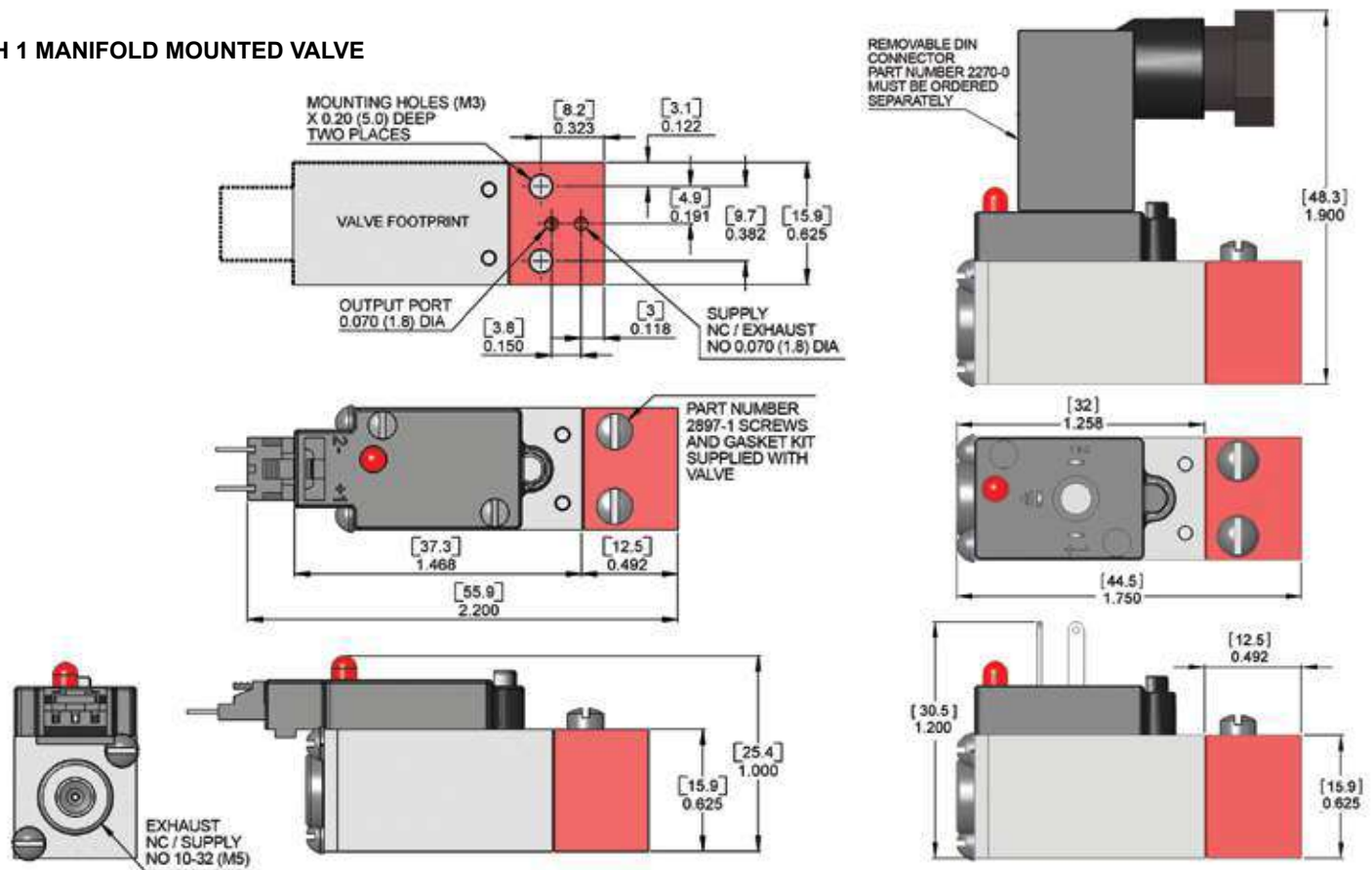

10-32 (M5) SINGLE SIDED MANIFOLD

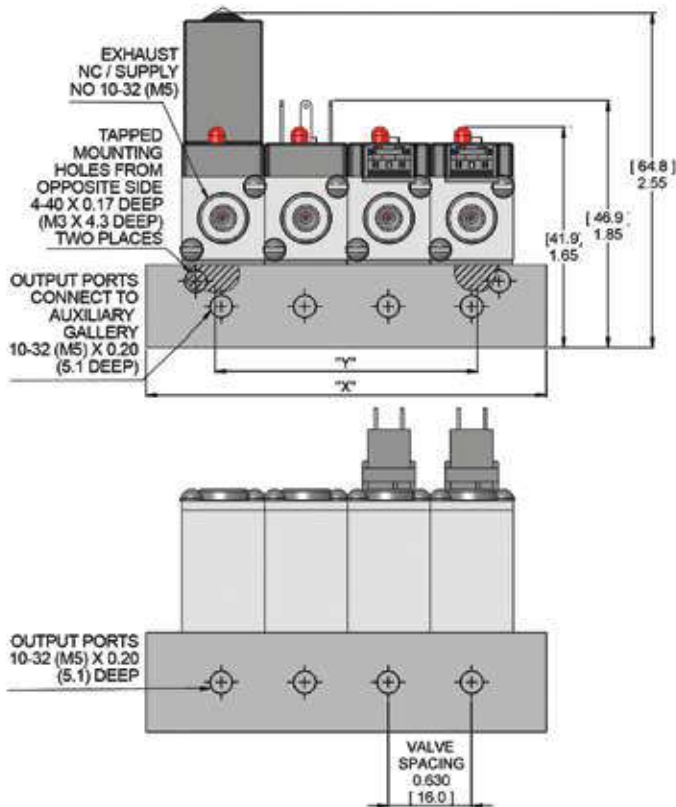

DASH 1 MANIFOLD [M5] 10-32 SINGLE SIDED			
Part Number	Number of Stations	"X"	"Y"
2529-2	2	1.260 (32.0)	1.008 (25.6)
2529-3	3	1.890 (48.0)	1.638 (41.6)
2529-4	4	2.520 (64.0)	2.268 (57.6)
2529-5	5	3.150 (80.0)	2.898 (73.6)
2529-6	6	3.780 (96.0)	3.528 (89.6)

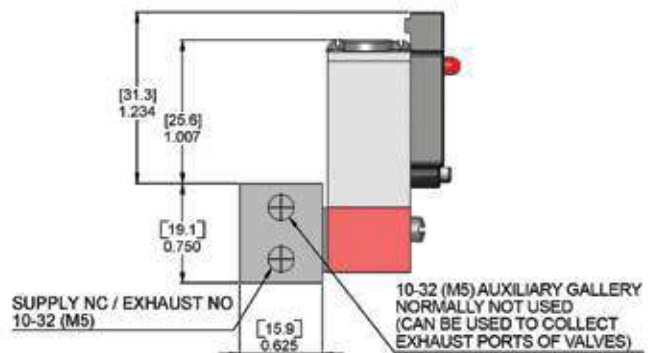



Dash 1 Manifolds

1/8 PIPE SINGLE SIDED MANIFOLD

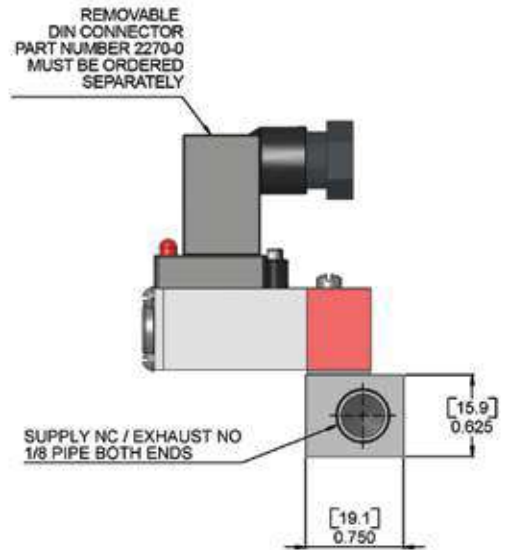
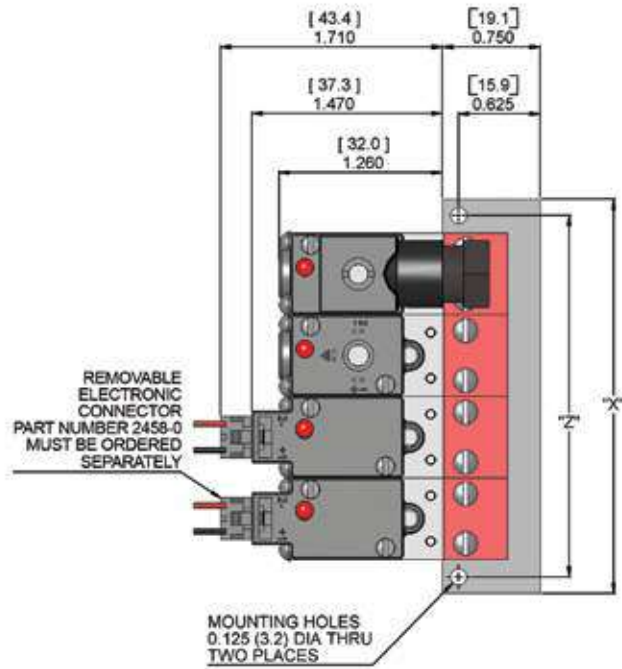
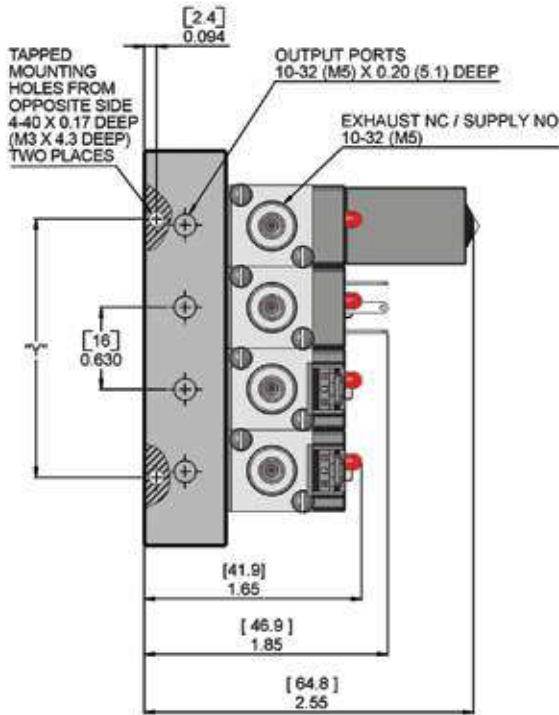

DIMENSIONS SHOWN IN INCHES [METRIC]

DASH 1 MANIFOLD 1/8 PIPE SUPPLY SINGLE SIDED					
NPT P/N	BSP P/N	Number of Stations	"X"	"Y"	"Z"
2511-2	2553-2	2	1.760 (44.7)	.630 (16.0)	1.510 (38.4)
2511-4	2553-4	4	3.020 (76.7)	1.890 (48.0)	2.770 (70.4)
2511-6	2553-6	6	4.280 (108.7)	3.150 (80.0)	4.030 (102.4)
2511-8	2553-8	8	5.540 (140.7)	4.410 (112.0)	5.290 (134.4)
2512-0	2554-0	10	6.800 (172.7)	5.670 (144.0)	6.550 (166.4)

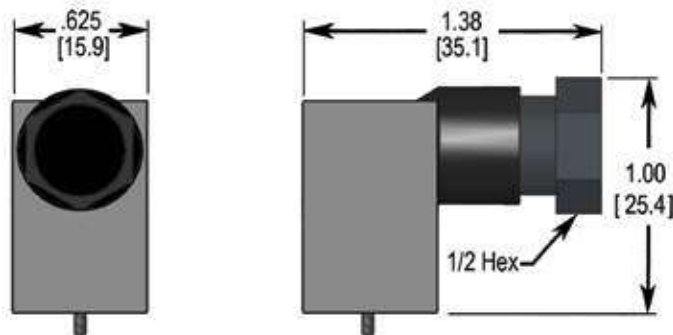

POS DIN CONNECTOR P/N 2270-0

2550-0 BLANK STATION COVER

Order part number 2550-0 for the complete blank station cover assembly. The assembly consists of:

- 2550-1 Blank Station Cover
- 2677-1 M3 Machine Screws (2 pieces)
- 2486-0 Gasket

Dash 1 Manifolds



1/8 PIPE DOUBLE SIDED MANIFOLD

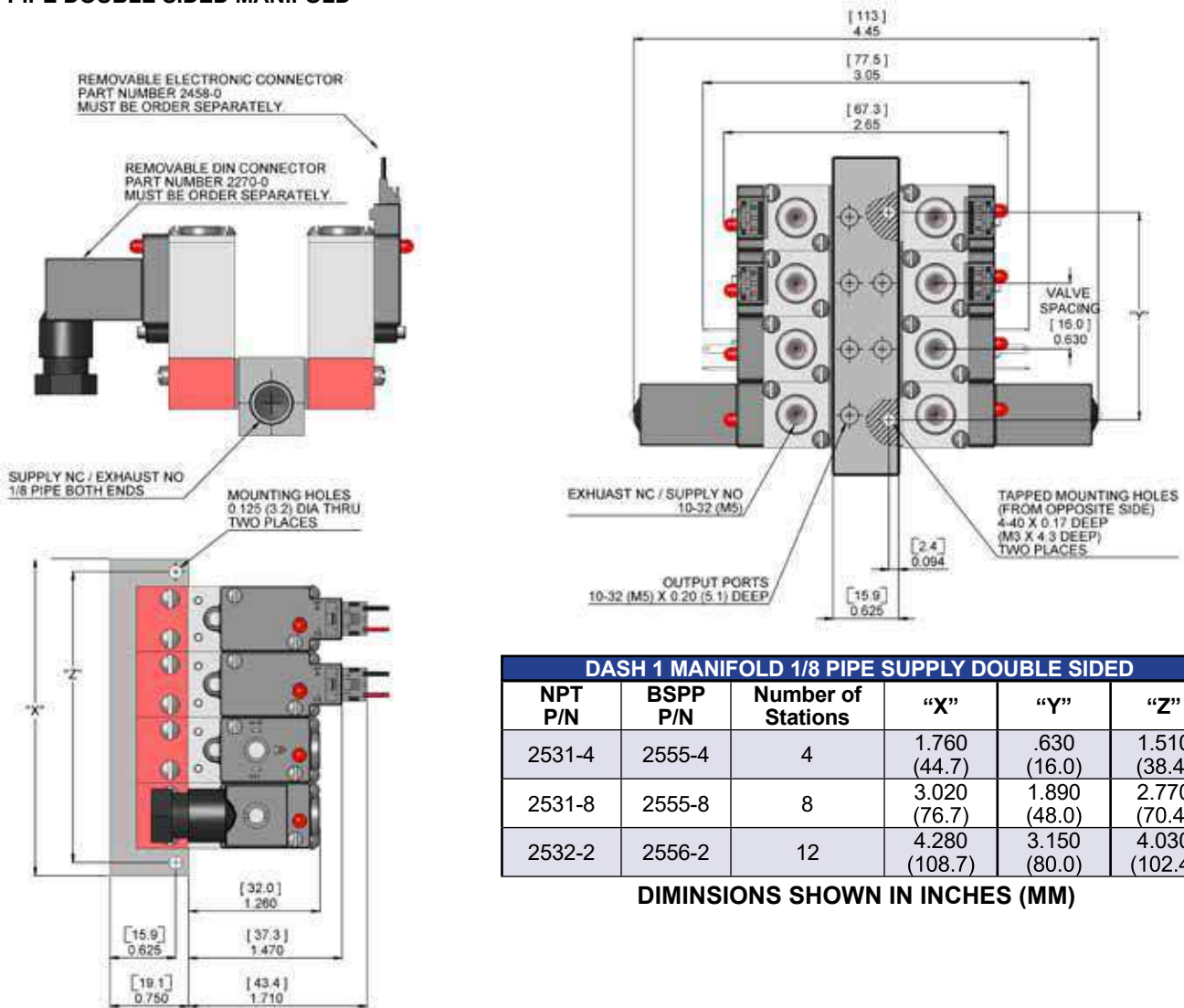

DASH 1 MANIFOLD 1/8 PIPE SUPPLY DOUBLE SIDED					
NPT P/N	BSPP P/N	Number of Stations	"X"	"Y"	"Z"
2531-4	2555-4	4	1.760 (44.7)	.630 (16.0)	1.510 (38.4)
2531-8	2555-8	8	3.020 (76.7)	1.890 (48.0)	2.770 (70.4)
2532-2	2556-2	12	4.280 (108.7)	3.150 (80.0)	4.030 (102.4)

DIMINIONS SHOWN IN INCHES (MM)

SINGLE IN-LINE MANIFOLD

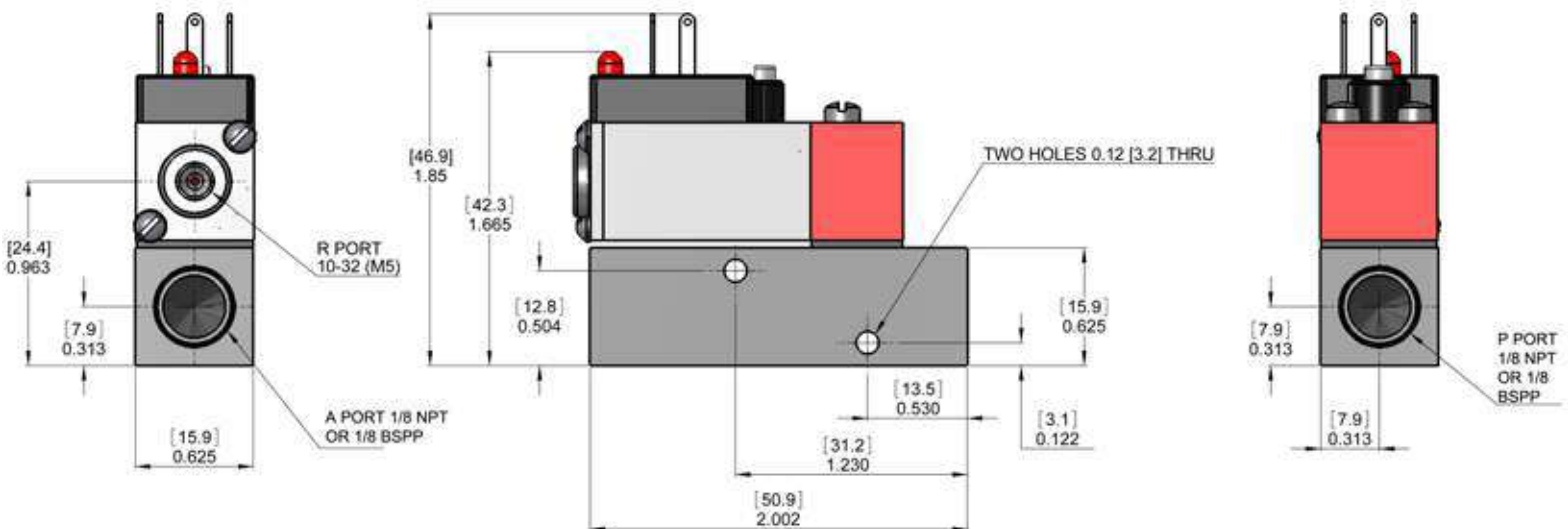



Central Connectors

DYNAMCO 15 AND 25 PIN CENTRAL CONNECTORS

This system is to enable valve control for up to 20 valves from a single D-Sub connector with the use of a PC or PLC control. This reduces the need for unnecessary wiring as there is only one cable for each assembly. Models are available with diode protection and can be assembled with either sinking or sourcing configuration. This compact, space saving unit is ideal for applications which use multiple valves controlled by a single source.



15 pin central connector shown with DASH-1 valves



25 pin central connector shown with DASH-2 valves

Central Connectors



DASH 1 CENTRAL CONNECTOR MODEL NUMBERS

CONNECTOR EXAMPLE:



VALVE BOARD EXAMPLE:

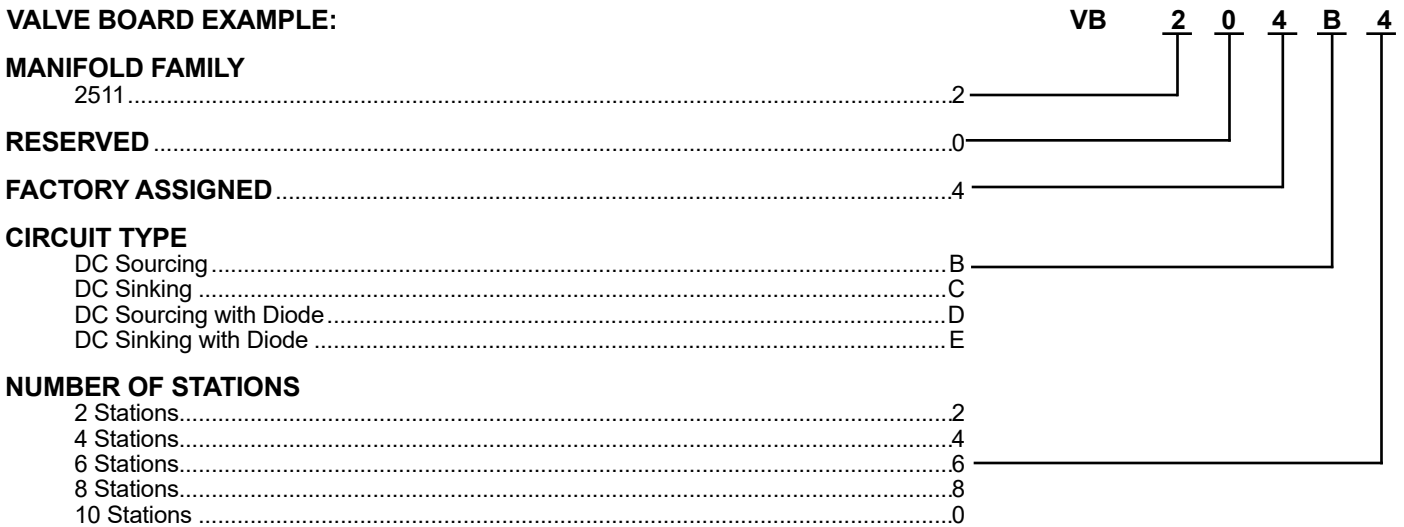



Central Connectors

D-SUB MALE CONNECTOR 15 PIN NUMBERING SYSTEM

PIN NO.	DC POWER SOURCE	
	Sinking Configuration (Switches "+")	Sourcing Configuration (Switches "-")
1	Not Used	Not Used
2	(+) Switches Valve 10 Solenoid	(-) Switches Valve 10 Solenoid
3	(+) Switches Valve 9 Solenoid	(-) Switches Valve 9 Solenoid
4	(+) Switches Valve 8 Solenoid	(-) Switches Valve 8 Solenoid
5	(+) Switches Valve 7 Solenoid	(-) Switches Valve 7 Solenoid
6	(+) Switches Valve 6 Solenoid	(-) Switches Valve 6 Solenoid
7	(-) Common	(+) Common
8	Not Used	Not Used
9	(+) Switches Valve 1 Solenoid	(-) Switches Valve 1 Solenoid
10	(+) Switches Valve 2 Solenoid	(-) Switches Valve 2 Solenoid
11	(+) Switches Valve 3 Solenoid	(-) Switches Valve 3 Solenoid
12	(+) Switches Valve 4 Solenoid	(-) Switches Valve 4 Solenoid
13	(+) Switches Valve 5 Solenoid	(-) Switches Valve 5 Solenoid
14	(-) Common	(+) Common
15	(-) Common	(+) Common

*Valve numbering begins with valve number 1 closest to the D-Sub Connector

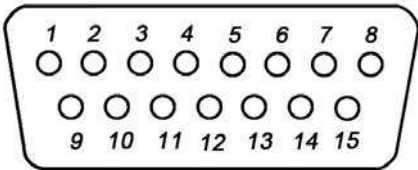

Central Connectors



DASH 2 / DASH 3 CENTRAL CONNECTOR MODEL NUMBERS

CONNECTOR EXAMPLE:

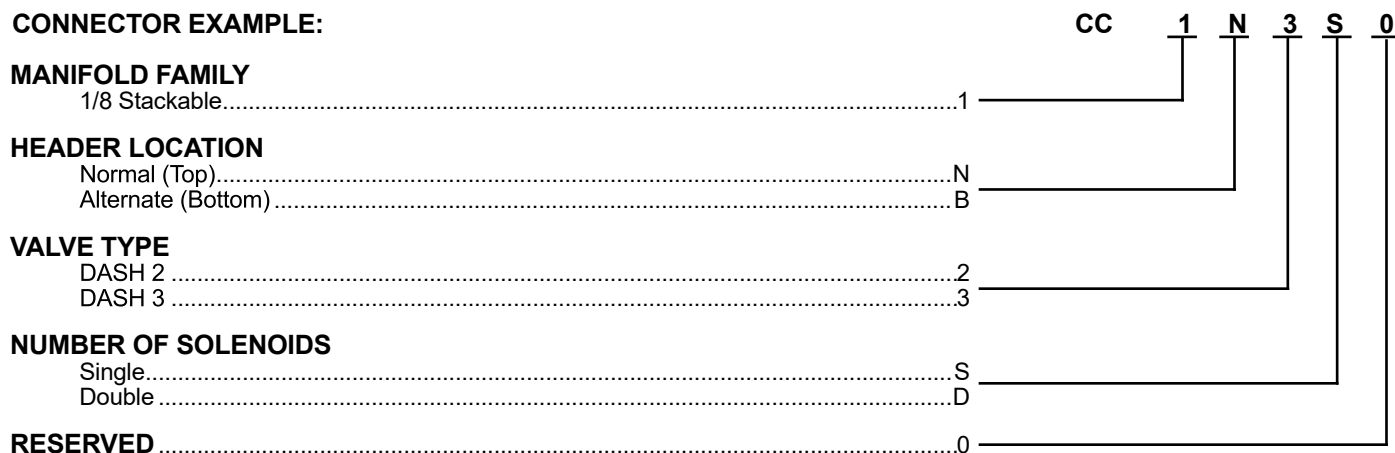

VALVE BOARD EXAMPLE:

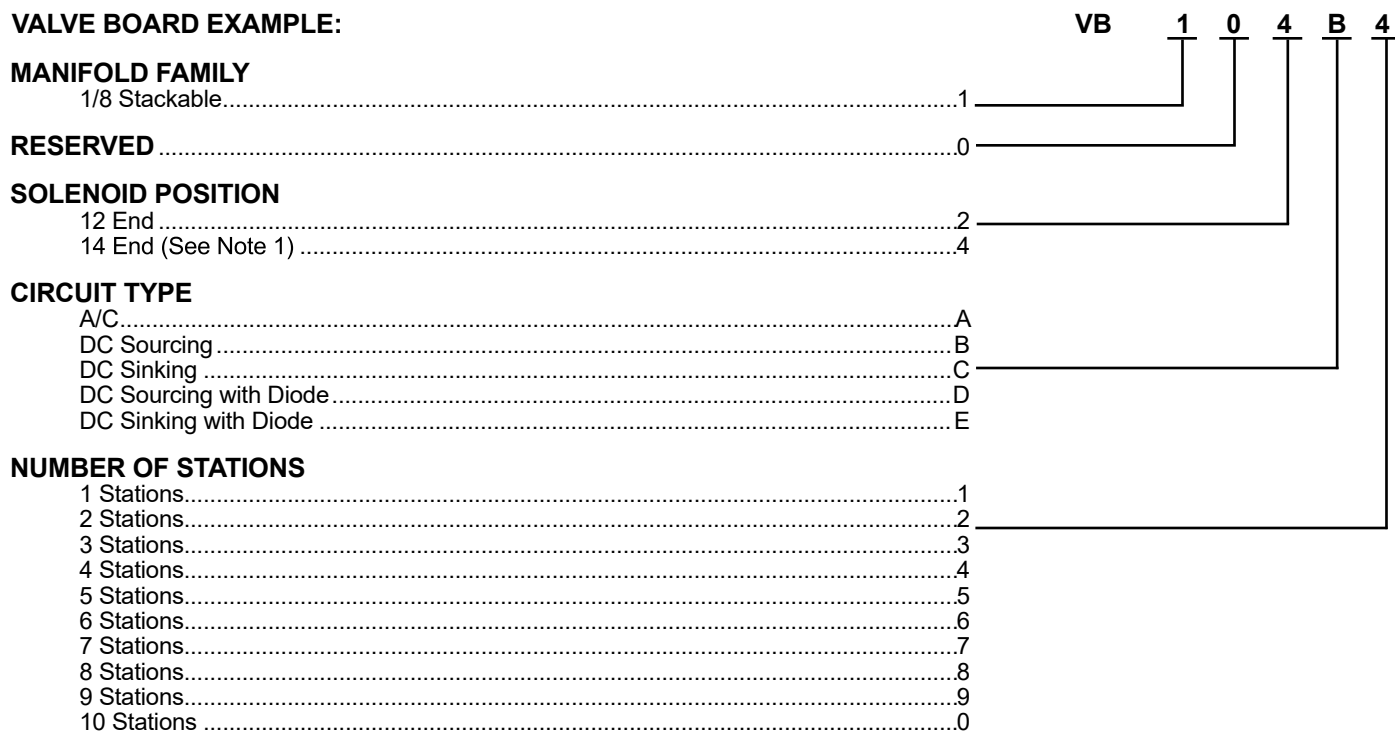

Note 1: This is referenced to the "normal" end.



Central Connectors

D-SUB MALE CONNECTOR 25 PIN NUMBERING SYSTEM

PIN NO.	DC POWER SOURCE		A/C POWER SOURCE
	Sinking Configuration (Switches "+")	Sourcing Configuration (Switches "-")	A/C Configuration
1	(+) Switches Valve 1 Solenoid 12	(-) Switches Valve 1 Solenoid 12	Signal Switches Valve 1 Solenoid 12
2	(+) Switches Valve 2 Solenoid 12	(-) Switches Valve 2 Solenoid 12	Signal Switches Valve 2 Solenoid 12
3	(+) Switches Valve 3 Solenoid 12	(-) Switches Valve 3 Solenoid 12	Signal Switches Valve 3 Solenoid 12
4	(+) Switches Valve 4 Solenoid 12	(-) Switches Valve 4 Solenoid 12	Signal Switches Valve 4 Solenoid 12
5	(+) Switches Valve 5 Solenoid 12	(-) Switches Valve 5 Solenoid 12	Signal Switches Valve 5 Solenoid 12
6	(-) Common	(+) Common	Common Ground
7	(-) Common	(+) Common	Common Ground
8	(-) Common	(+) Common	Common Ground
9	(+) Switches Valve 5 Solenoid 14	(-) Switches Valve 5 Solenoid 14	Signal Switches Valve 5 Solenoid 14
10	(+) Switches Valve 4 Solenoid 14	(-) Switches Valve 4 Solenoid 14	Signal Switches Valve 4 Solenoid 14
11	(+) Switches Valve 3 Solenoid 14	(-) Switches Valve 3 Solenoid 14	Signal Switches Valve 3 Solenoid 14
12	(+) Switches Valve 2 Solenoid 14	(-) Switches Valve 2 Solenoid 14	Signal Switches Valve 2 Solenoid 14
13	(+) Switches Valve 1 Solenoid 14	(-) Switches Valve 1 Solenoid 14	Signal Switches Valve 1 Solenoid 14
14	(+) Switches Valve 6 Solenoid 12	(-) Switches Valve 6 Solenoid 12	Signal Switches Valve 6 Solenoid 12
15	(+) Switches Valve 7 Solenoid 12	(-) Switches Valve 7 Solenoid 12	Signal Switches Valve 7 Solenoid 12
16	(+) Switches Valve 8 Solenoid 12	(-) Switches Valve 8 Solenoid 12	Signal Switches Valve 8 Solenoid 12
17	(+) Switches Valve 9 Solenoid 12	(-) Switches Valve 9 Solenoid 12	Signal Switches Valve 9 Solenoid 12
18	(+) Switches Valve 10 Solenoid 12	(-) Switches Valve 10 Solenoid 12	Signal Switches Valve 10 Solenoid 12
19	Not Used	Not Used	Not Used
20	Not Used	Not Used	Not Used
21	(+) Switches Valve 10 Solenoid 14	(-) Switches Valve 10 Solenoid 14	Signal Switches Valve 10 Solenoid 14
22	(+) Switches Valve 9 Solenoid 14	(-) Switches Valve 9 Solenoid 14	Signal Switches Valve 9 Solenoid 14
23	(+) Switches Valve 8 Solenoid 14	(-) Switches Valve 8 Solenoid 14	Signal Switches Valve 8 Solenoid 14
24	(+) Switches Valve 7 Solenoid 14	(-) Switches Valve 7 Solenoid 14	Signal Switches Valve 7 Solenoid 14
25	(+) Switches Valve 6 Solenoid 14	(-) Switches Valve 6 Solenoid 14	Signal Switches Valve 6 Solenoid 14

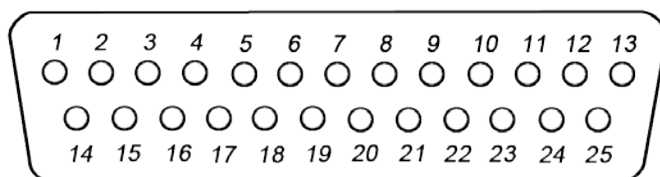

*Valve numbering begins with valve number 1 closest to the D-Sub Connector.

Central Connectors

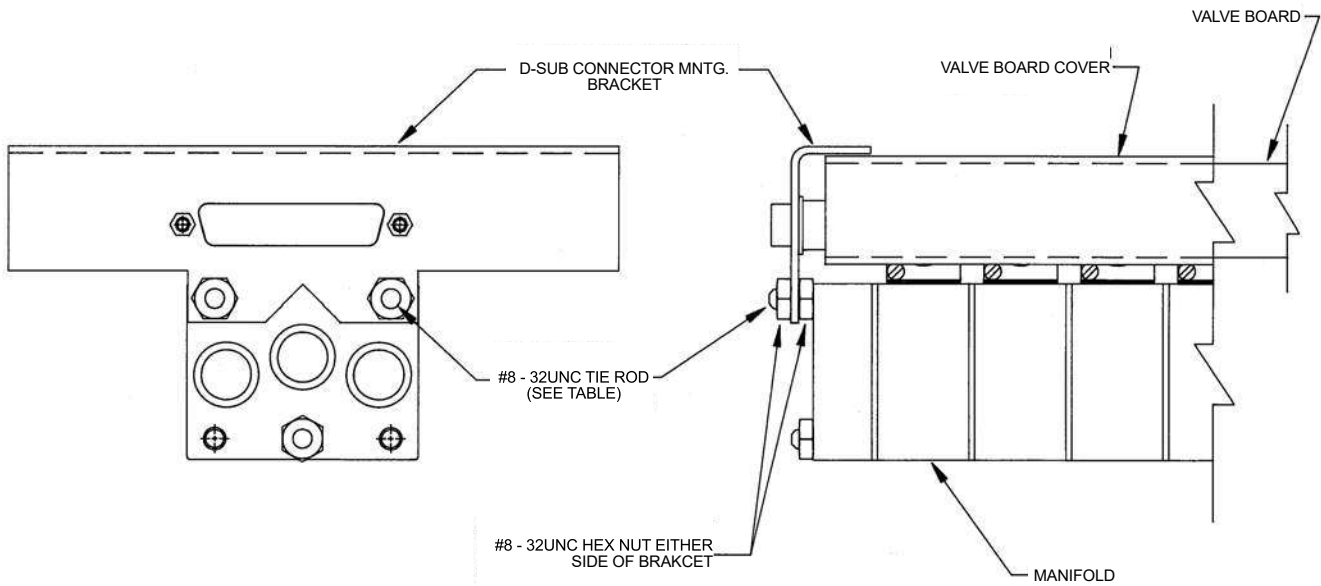
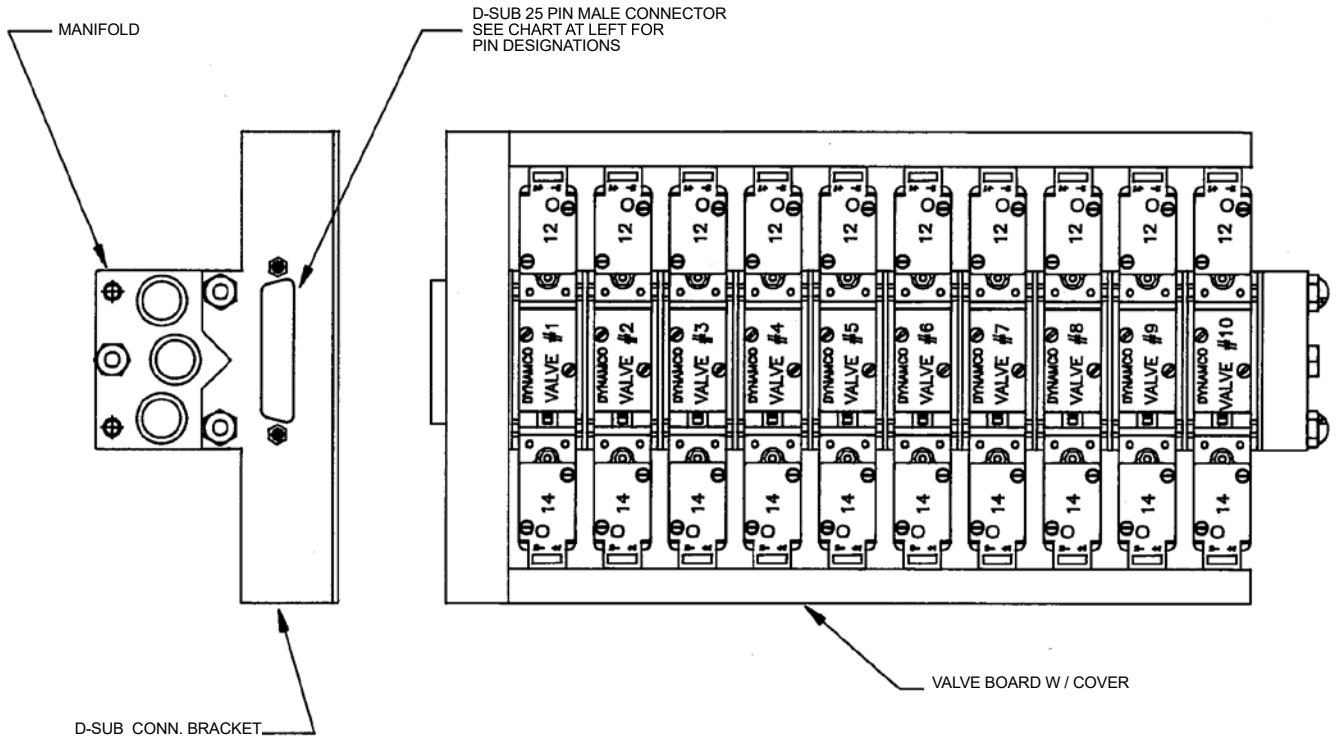

Dimensions are in inches (mm).

WHAT IS A BLEED/FEED VALVE?

A Bleed/Feed valve acts as a 3-way, 3-position, closed center control valve, with two solenoid operators. As illustrated in the pictures to the right, the Bleed/Feed valve is essentially two DASH 1 valves that have been mounted together with special porting, depending on customer requirements.

HOW DOES IT WORK?

Each Bleed/Feed valve has 3 ports and two solenoids. There are two primary configurations: *standard* and *fail-safe*.

Standard configuration: The air source is supplied to the supply port. When the “fill” solenoid is energized, air flows from the supply port to the actuator port. When the “exhaust” solenoid is energized, air flows from the actuator port to the exhaust port. When neither solenoid is energized, the valve is in a closed position, with no flow passing through the valve.

Fail-safe configuration*: performs the same function, but is designed to exhaust when neither solenoid is energized. As before, the air supply enters the valve at the supply port. When both the fill and exhaust solenoids are energized together, air flows from the supply port to the actuator port. When only the exhaust solenoid is energized, the valve is in the closed position, with no flow passing through the valve. Finally, when neither solenoid is energized, the air flow flows from the actuator port to the exhaust port.

Applications abound for this type of control and we have been involved with customers driving pump systems for medical applications, designing industrial pressure transducers, and even controlling suspension systems for automobiles.

*Not shown

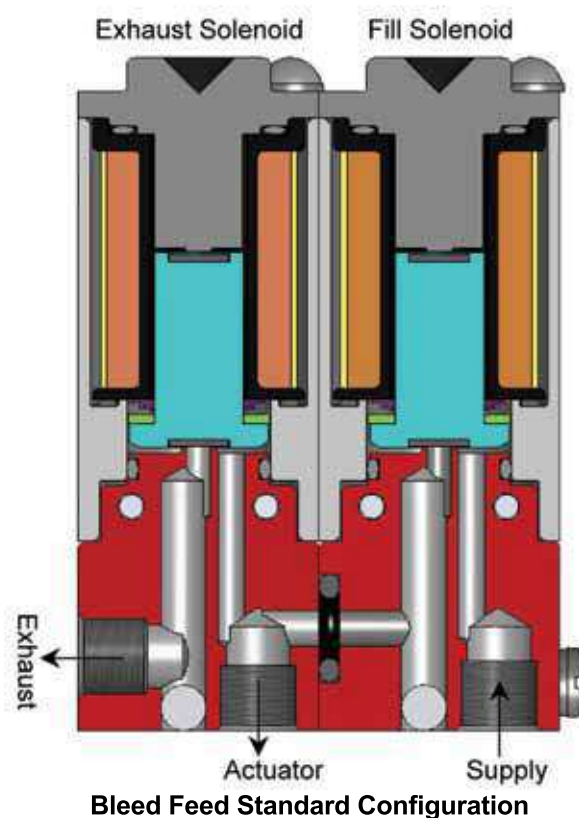
**TYPICAL APPLICATIONS:**

EMT Simulations

HVAC Controls

Air Suspension Systems

Blood Pressure Monitors

Cylinder Positioning

Emissions Analysis

Kidney Dialysis Machines

Air Springs

Lumbar Support Systems

Bleed/Feed Valve



EXAMPLE: **BF1 3 2 02**

VALVE TYPE

(See Valve Characteristics Below)

- BF1
- BF2
- BF3
- BF4
- BF5

VALVE PORT AND MOUNTING

- Ports in Body, Screw Mount.....02
- Ports in Body, P.C. Board Mount.....06

VOLTAGE (For Both Coils)

- 5 VDC.....1
- 12 VDC.....2
- 24 VDC.....3
- 5 VDC with Diode.....A
- 12 VDC with Diode.....B
- 24 VDC with Diode.....C

CONNECTOR (For Both Coils)

- Electronic.....2
 - DIN.....3
 - P.C. Board Mount.....4
- Note: Flying Leads are also available. For more information, please consult Dynamco.*

Valve Type	Valve Function	Orifice in (MM)	Power (Watts)	Allowable Output SUP Difference
BF1	EXH. N.C.	.031 (0.8)	0.6	50 psi
BF2	EXH. N.C.	.062 (1.6)	2.5	20 psi
BF3	EXH. N.C.	.031 (0.8)	1.2	75 psi
BF4	EXH. N.C.	.062 (1.6)	1.2	20 psi
BF5	EXH. N.C.	.089 (2.3)	2.5	10 psi

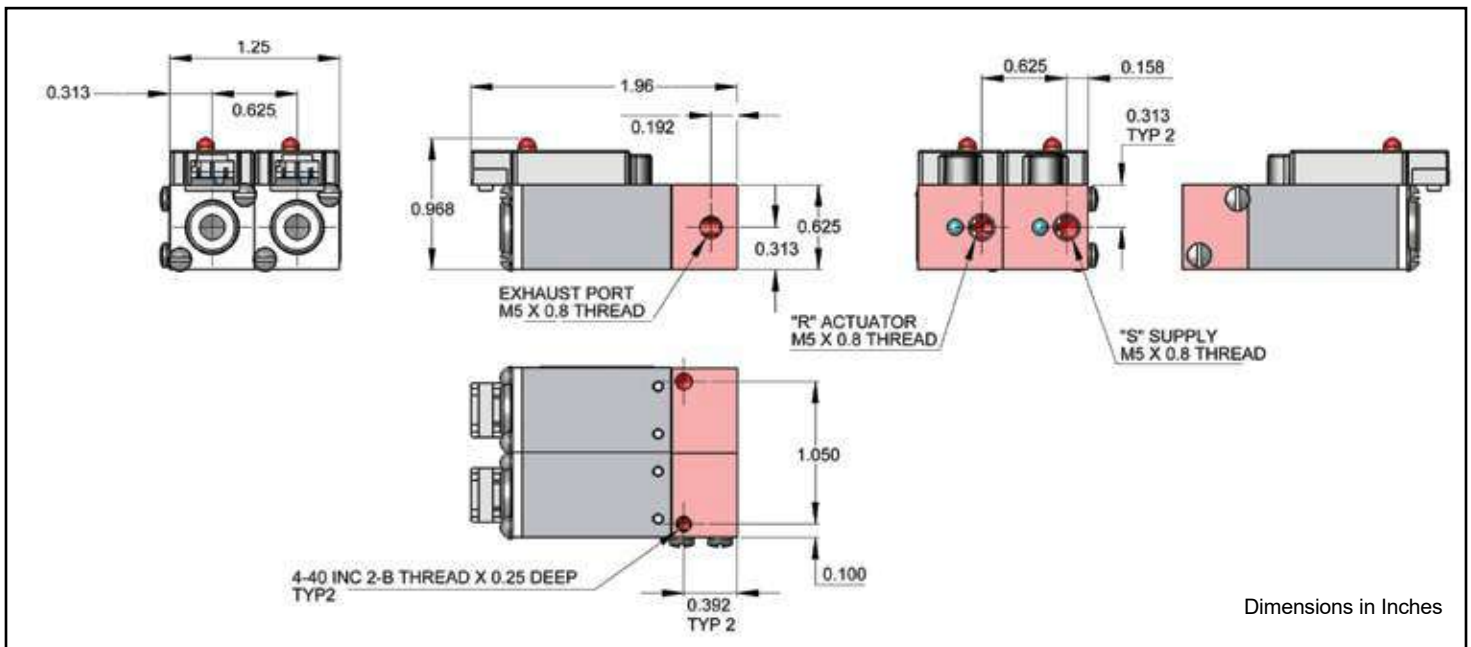
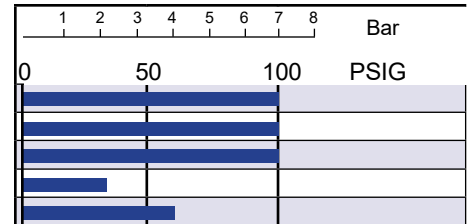



Dash 2 Valves

DASH 2 OPERATED SOLENOID VALVE QUALITY DESIGN FEATURES

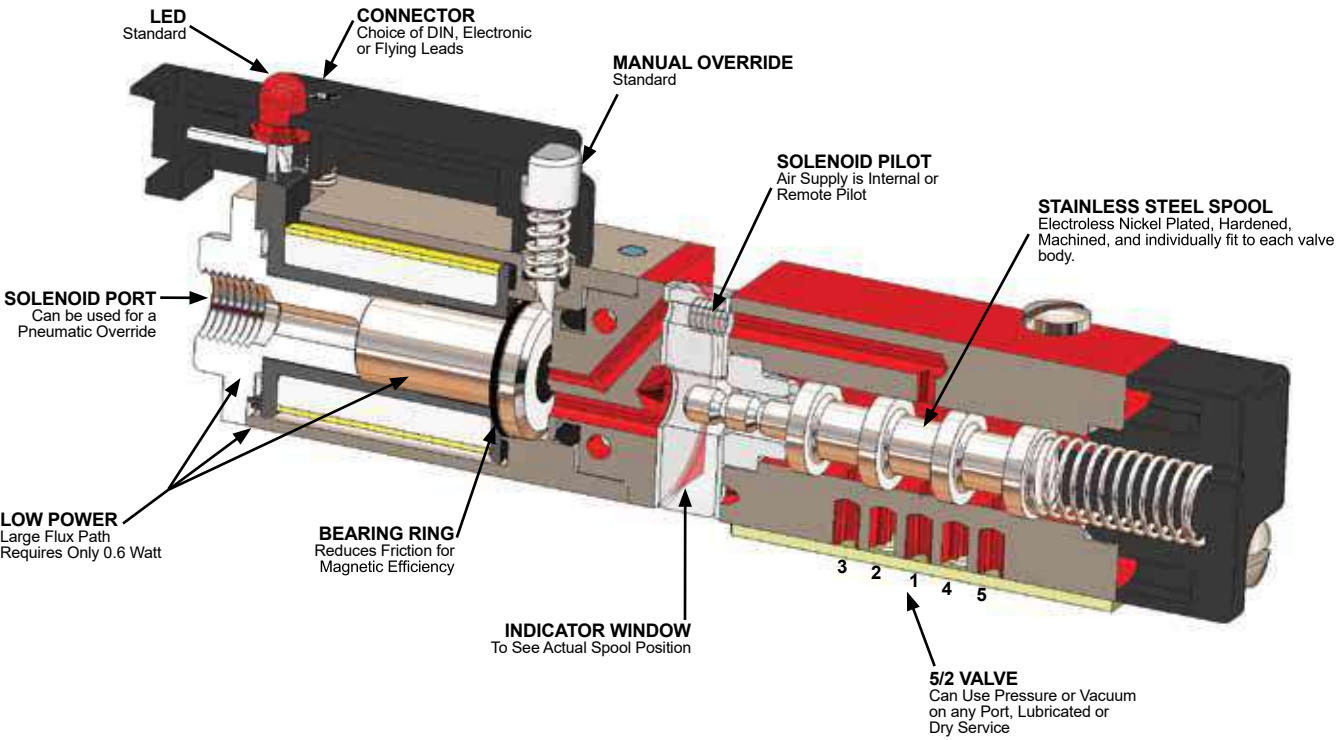

DASH 1 SOLENOID OPERATOR
Solenoid Life 100,000,000 Cycles

HIGH FLOW Cv=.12
7 SCFM (200 LPM) .100 Inch (2.5 mm) Dia.
(See Flow Curves Page 23)

MANIFOLDS
For Mounting and Connecting Multiple Valves

MINATURE SIZE
.625 in. (16 mm) Wide

BASEPLATES
Choice of Side and Bottom Ports

FAST RESPONSE
.004 - .007 Sec. to Shift

Dash 2 Valves



D2532KLO DASH 2 Single POS Solenoid Electronic
2593-0 1/8 NPT Side Ported Base
2458-0 Removable Electronic Connector



D2533KLO DASH 2 SINGLE POS SOLENOID DIN
2430-0 10-32 [M5] Bottom Ported Base
2270-0 Removable DIN Connector



VALVE BODY AND SPOOL DESIGN

There are no moving seals in the DASH 2 valve! The DASH 2 is a metal-to-metal lapped spool valve. Traditional metal-to-metal valves can be unforgiving and require extremely fine filtration. Dynamco's design of using dissimilar metals of different hardnesses eliminates the need. DYNAMCO controls the clearances between the body and spool by individually match fitting each spool and body to achieve a proper floating air bearing. The clearance has a narrow range that every valve must achieve. The thermal expansion coefficients of the body and spool are the same, so the clearance stays the same over a wide range of temperatures.

MINIATURE SIZE AND HIGH FLOW

DASH 2 valves are .625 inches (16mm) wide and yet have a C_v of .12 that will flow over 7 SCFM (200 Liters/Min). See Flow Curves on page 23.

SPEED

DASH 2 valves are extremely fast. The pilot operated solenoid DASH 2 can shift in 4 to 7 milliseconds. Higher pressures result in faster the shift times.

REPEATABILITY

In DYNAMCO's DASH 2 valves, virtually all friction has been eliminated. The only force on the spool is the spring and the air pressure from the solenoid pilot. Valves with moving seals not only endure friction, but friction changes with lubrication, moisture, temperature, etc. DYNAMCO valves respond the same regardless of ambient conditions.

LOW ELECTRICAL POWER REQUIREMENTS

The very low 0.6 watt power consumption of the pilot operated solenoid allows DASH 2 valves to be controlled by almost any electronic control.

LIFE

The design life of DYNAMCO's DASH 2 valves is well in excess of 100 million cycles. This performance has been thoroughly proven in laboratory tests and field performance.

LED INDICATOR

DASH 2 valves have a red LED as a standard feature.

Note: Take care to connect the positive wire (red) to the #1 (positive) terminal and the negative wire (black) to the #2 (negative) terminal when attaching the signal wires to the connector. If the polarity is reversed, the valve will work, but the LED will not illuminate. If the LED appears dim, check the voltage level supplied to the solenoid. It is probably below the minimum rated level.

SPOOL INDICATOR WINDOW

The spool indicator window shows the physical position of the spool, and is a great benefit when setting up and troubleshooting machines.

SOLENOID PILOT AIR

The DASH 2 valve can be ordered with a main supply connection or a remote pilot connection, and configuration can be switched in the field without any additional parts.

PNEUMATIC OVERRIDE

The solenoid operator port can be used for a pneumatic override. A 3 way (3/2) signal will shift the valve spool against the return spring (or detent in a double solenoid).

QUALITY

Quality must be present in both design and manufacturing. Our strict standards ensure the DASH 2 valve is the highest quality design available. **We are an ISO 9001:2008 certified company.**

DYNAMCO manufactures practically all components for DASH 2 in its own manufacturing facility. Every DASH 2 is given a complete battery of tests at various stages of manufacture. DYNAMCO's care and attention to detail mean you receive a thoroughly proven product when it is finally given the DYNAMCO name and packed for shipment.



Dash 2 Valves

DASH 2 PILOT OPERATED SOLENOID REMOTE SUPPLY

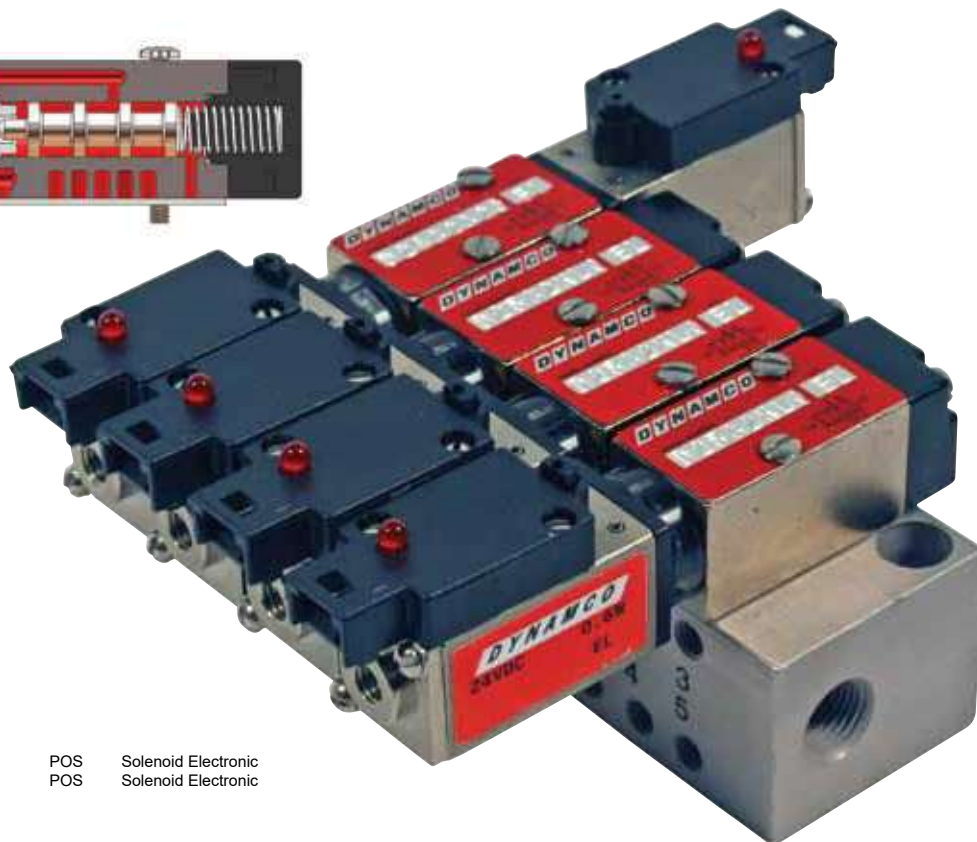
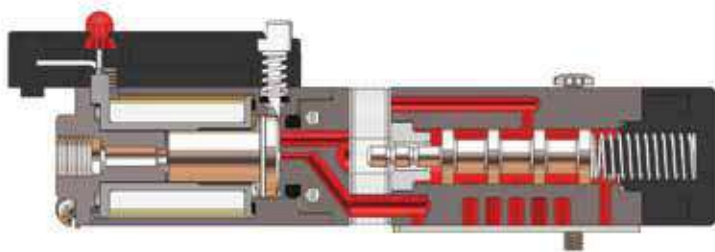

1466-4 MANIFOLD 4 STATION 10-32 [M5] PORTS

3 Valves	D2532KL0	Dash 2	Single	POS	Solenoid Electronic
1 Valve	D2632320	Dash 2	Double	POS	Solenoid Electronic

ELECTRICAL SPECIFICATIONS			
Voltage (Volts)	Power (Watts)	Resistance (OHMS)	Current (Amps)
5*	0.6	45	.111
12*	0.6	260	.050
24*	0.6	1100	.027
115*	2.5	5500	.021

*The voltage can be AC (50/60 Hz) or DC. For AC operation use AC lead wires (described on page 4) and the proper voltage DC DASH 2 valve. Voltage tolerance is +15% -10% of rated. Solenoids are rated for continuous duty.

TEMPERATURE RANGE

For DASH 2 Models below 1 watt:
0° to 150°F (-18° to 65°C)

For DASH 2 Models above 1 watt
0° to 122°F (-18° to 50°C)

MOUNTING

Generally, DASH 2 POS valves may be mounted in any orientation. DYNAMCO recommends mounting DASH 2 valve spools horizontally if vibration is present.

MATERIALS

Valve Body	Electroless Nickel Plated S.S.
Valve Spool	Hardened Stainless Steel
Springs	Stainless Steel
Seals	Buna N and Polyurethane
Indicator Window	Acrylic
Spring Housing.....	Delrin
Solenoid Adapter Plate	Anodized Aluminum
Solenoid Housing/Pole Piece	Plated S.S.
Armature	Proprietary
Coil Form.....	Ryton™ R4

PRESSURE RANGE

Spool Valvevacuum to 100 psi (6.9 Bar)
Min. Std. Solenoid Pilot Press20 psi (1.4 Bar)
For lower pilot pressure models, please contact DYNAMCO.

SERVICE, FILTRATION AND LUBRICATION

DASH 2 valves are designed for service on air and inert gasses. DYNAMCO recommends 5 micron filtration. Lubrication is not required.

Dash 2 Valves



DASH 2 POS MODEL NUMBERING SYSTEM

EXAMPLE: **D2 5 33 KL 0**

VALVE SERIES

VALVE TYPE

- Single POS - Connected to Main Supply 5
- Double POS - Connected to Main Supply 6
- Single POS - Connected to Pilot Supply 7
- Double POS - Connected to Pilot Supply 8

BASE PLATE OPTION

- Without Base Plate 0
- Bottom Ported 10-32 (M5) 2430-0 A
- Side Ported 10-32 (M5) 2592-0 B
- Side Ported 1/8 NPT 2593-0 D
- Side Ported 1/8 BSPP (G1/8) 2801-0 F

ACTUATOR "14" END

- 5 VDC 0.6 Watt Electronic 12
- 5 VDC 0.6 Watt DIN 13
- 12 VDC 0.6 Watt Electronic 22
- 12 VDC 0.6 Watt DIN 23
- 24 VDC 0.6 Watt Electronic 32
- 24 VDC 0.6 Watt DIN 33
- 115 VDC 2.5 Watt Electronic 52
- 115 VDC 2.5 Watt DIN 53
- 5 VDC 0.6 Watt Elec Conn w/Diode A2
- 5 VDC 0.6 Watt DIN Conn w/Diode A3
- 12 VDC 0.6 Watt Elec Conn w/Diode B2
- 12 VDC 0.6 Watt DIN Conn w/Diode B3
- 24 VDC 0.6 Watt Elec Conn w/Diode C2
- 24 VDC 0.6 Watt DIN Conn w/Diode C3
- No Solenoid - Adapter Plate Only XX

ACTUATOR "12" END

- 5 VDC 0.6 Watt Electronic 12
- 5 VDC 0.6 Watt DIN 13
- 12 VDC 0.6 Watt Electronic 22
- 12 VDC 0.6 Watt DIN 23
- 24 VDC 0.6 Watt Electronic 32
- 24 VDC 0.6 Watt DIN 33
- 115 VDC 2.5 Watt Electronic 52
- 115 VDC 2.5 Watt DIN 53
- 5 VDC 0.6 Watt Elec Conn w/Diode A2
- 5 VDC 0.6 Watt DIN Conn w/Diode A3
- 12 VDC 0.6 Watt Elec Conn w/Diode B2
- 12 VDC 0.6 Watt DIN Conn w/Diode B3
- 24 VDC 0.6 Watt Elec Conn w/Diode C2
- 24 VDC 0.6 Watt DIN Conn w/Diode C3
- Spring Return - Standard 20 psi* KL
- No Solenoid - Adapter Plate Only XX

*lower pressure models may be available. Please consult DYNAMCO for more information.

- NOTES:**
1. Removable connectors and lead wires must be ordered separately. See page 6.
 2. All voltages can be used on either AC or DC electrical service by ordering the proper AC or DC lead wires. See page 6.
 3. Note: Flying Leads are also available. For more information, please consult Dynamco.

0.100 in (2.5) Orifice

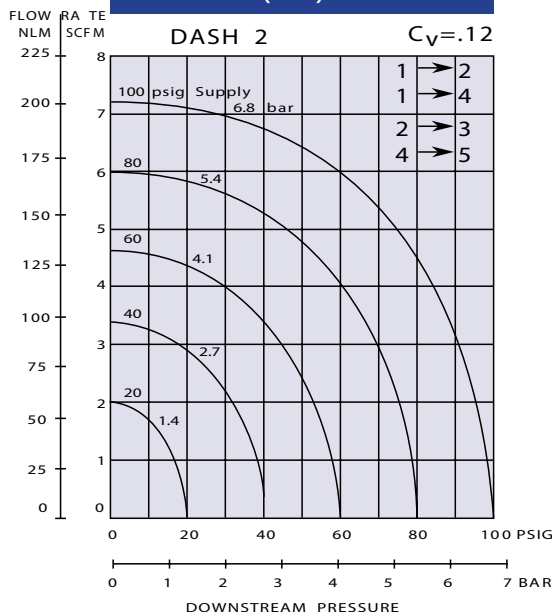

DASH 2 POS VALVE SYMBOLS

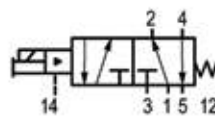

SINGLE SOLENOID
Remote Pilot Supply

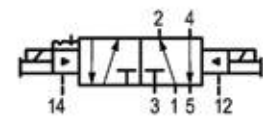

DOUBLE SOLENOID
Remote Pilot Supply

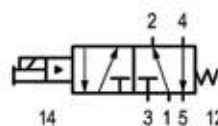

SINGLE SOLENOID
Main Supply

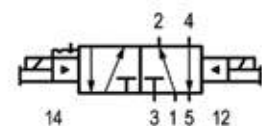

DOUBLE SOLENOID
Main Supply



Dash 2 Valves

DASH 2 AIR PILOT OPERATED VALVES QUALITY DESIGN FEATURES

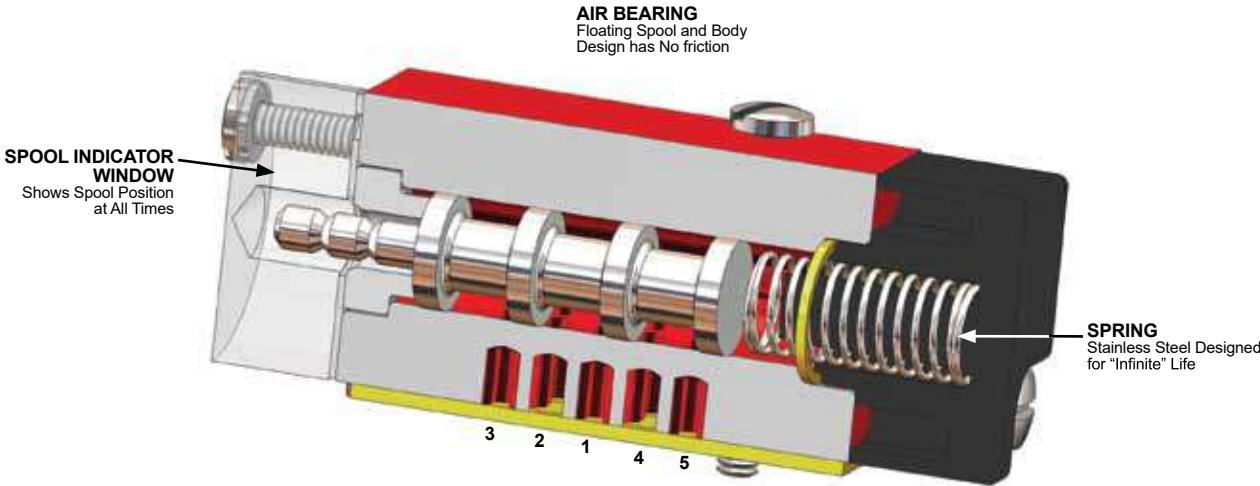

AIR PILOT OPERATED - SPRING RETURN

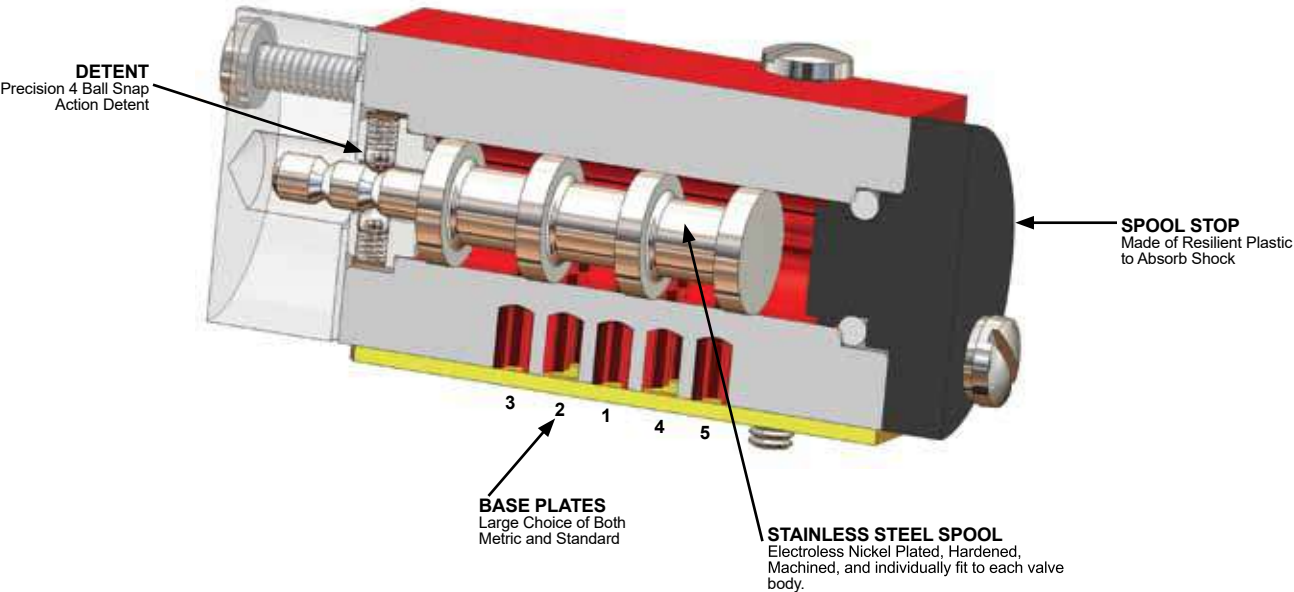

DOUBLE AIR PILOT - DETENTED

LIFE
100,000,000 Cycles

HIGH FLOW Cv=.12
7 SCFM (200 LPM) .100 Inch (2.5 mm) Dia.
(See Flow Curves Page 23)

MANIFOLD MOUNTING
For Mounting and Connecting
Multiple Valves

LUBRICATION
Not Required But May Be Used

REPEATABILITY
Excellent because the valves have
no friction and the parts are
thermally matched

FAST RESPONSE
.003 - .005 Sec. to Shift

Dash 2 Valves



D20S0K00 DASH 2 Double Air Piloted
2593-0 1/8 NPT Side Ported Base



D20S0K00 DASH 2 AIR PILOTED SPRING RETURN
2430-0 10-32 [M5] Bottom Ported Base

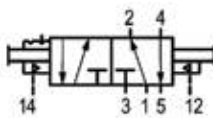

**DOUBLE AIR PILOT
DETENTED**

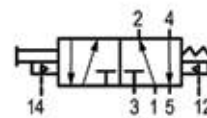

**AIR PILOT
SPRING RETURN**

DASH 2 AIR PILOT MODEL NUMBERING SYSTEM

EXAMPLE: **D20SMK0** **0**

VALVE SERIES

Dash 2 Air Pilot Operated Spring Return.....	D20S0K0
Dash 2 Air Pilot Operated Spring Return with Manual Override	D20SMK0
Dash 2 Double Air Pilot Detented	D20D0A0
Dash 2 Double Air Pilot Detented with Manual Overrides.....	D20DMAM

BASE PLATE OPTION

Without Base Plate	0
Bottom Ported 10-32 (M5) 2430-0.....	A
Side Ported 10-32 (M5) 2592-0.....	B
Side Ported 1/8 NPT 2593-0.....	D
Side Ported 1/8 BSPP (G1/8) 2801-0.....	F

MATERIALS

Valve Body	Electroless Nickel Plated S.S.
Valve Spool	Hardened Stainless Steel
Springs	Stainless Steel
Seals	Buna N and Polyurethane
Indicator Window	Acrylic
Spring Housing.....	Delrin

PRESSURE RANGE

Spool Valvevacuum to 100 psi (6.9 Bar)
 Minimum Standard Pilot Press20 psi (1.4 Bar)
 For lower pilot pressure models, please contact
 DYNAMCO.

SERVICE, FILTRATION AND LUBRICATION

DASH 2 valves are designed for service on air and inert gasses. DYNAMCO recommends 5 micron filtration. Lubrication is not required.

TEMPERATURE RANGE

0° to 200°F (-18° to 93°C)

MOUNTING

Generally DASH 2 air piloted valves may be mounted in any orientation. DYNAMCO recommends mounting valve spools horizontally if vibration is present.



Dash 2 Baseplates

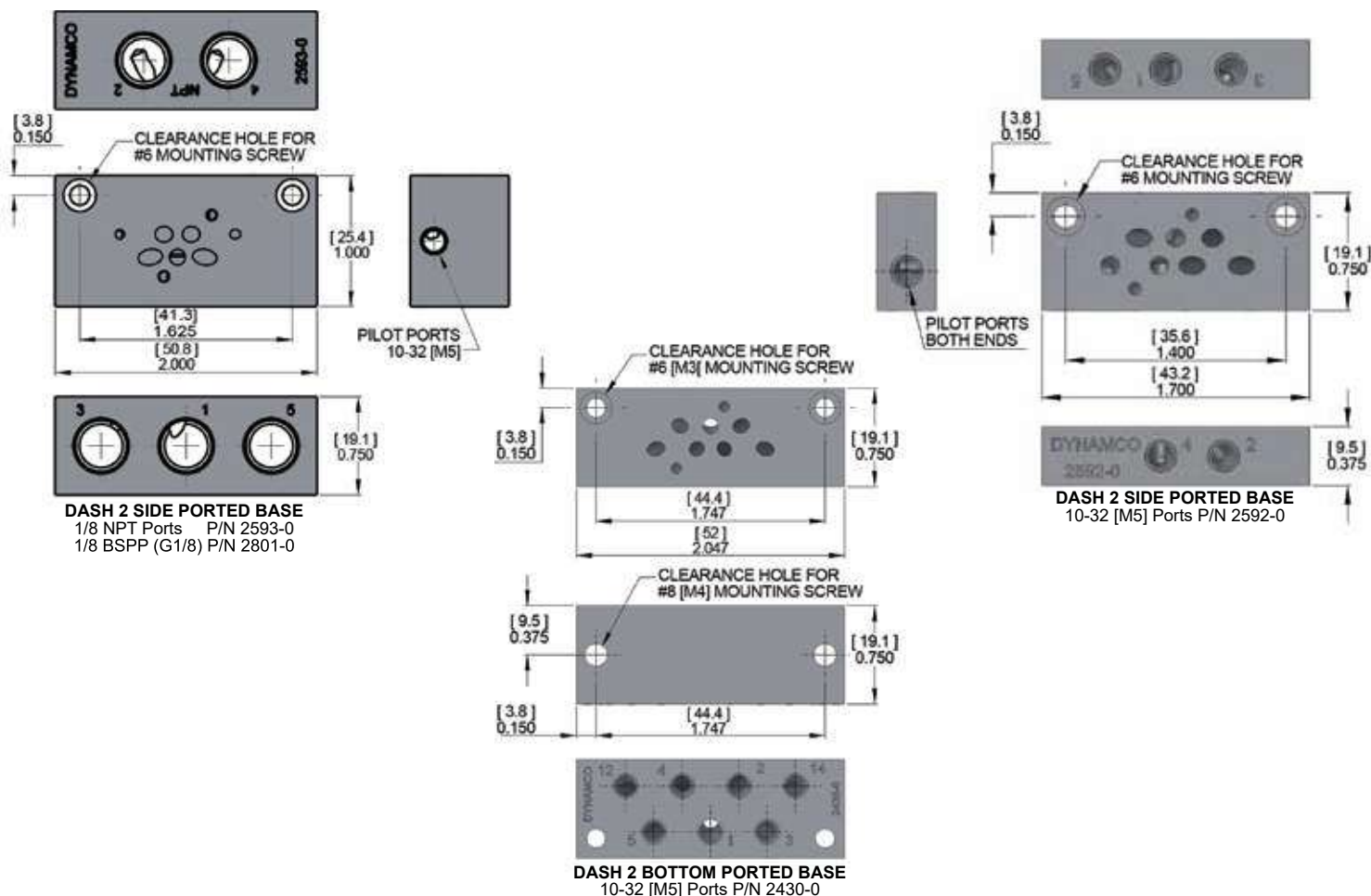

DASH2 FOOTPRINT

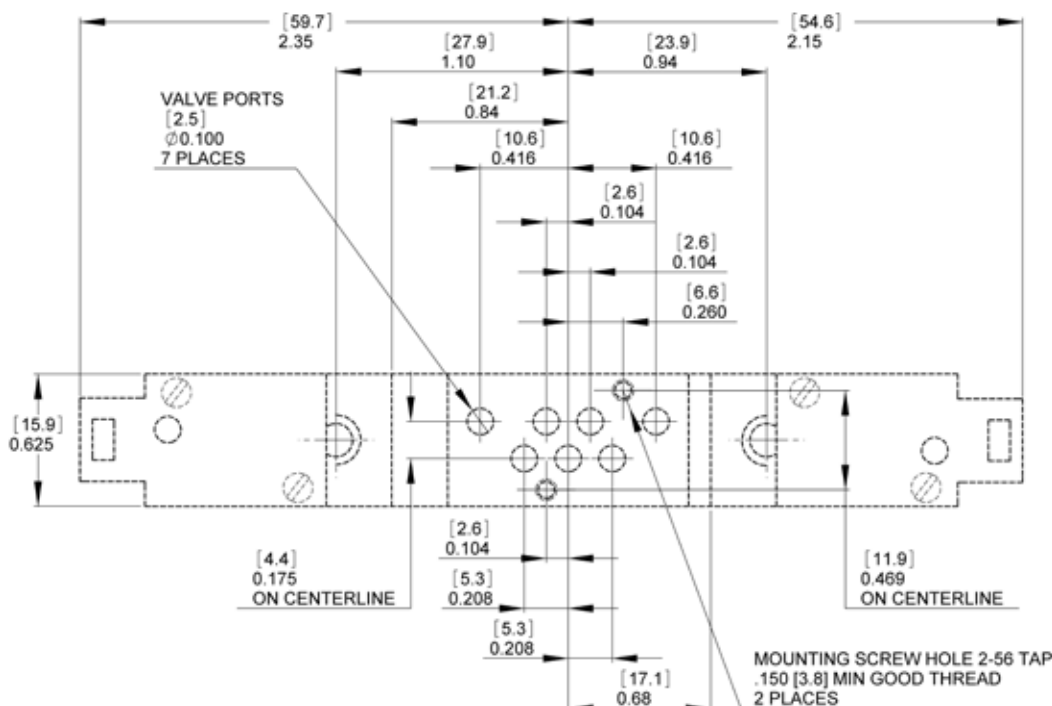

Dash 2 Manifolds

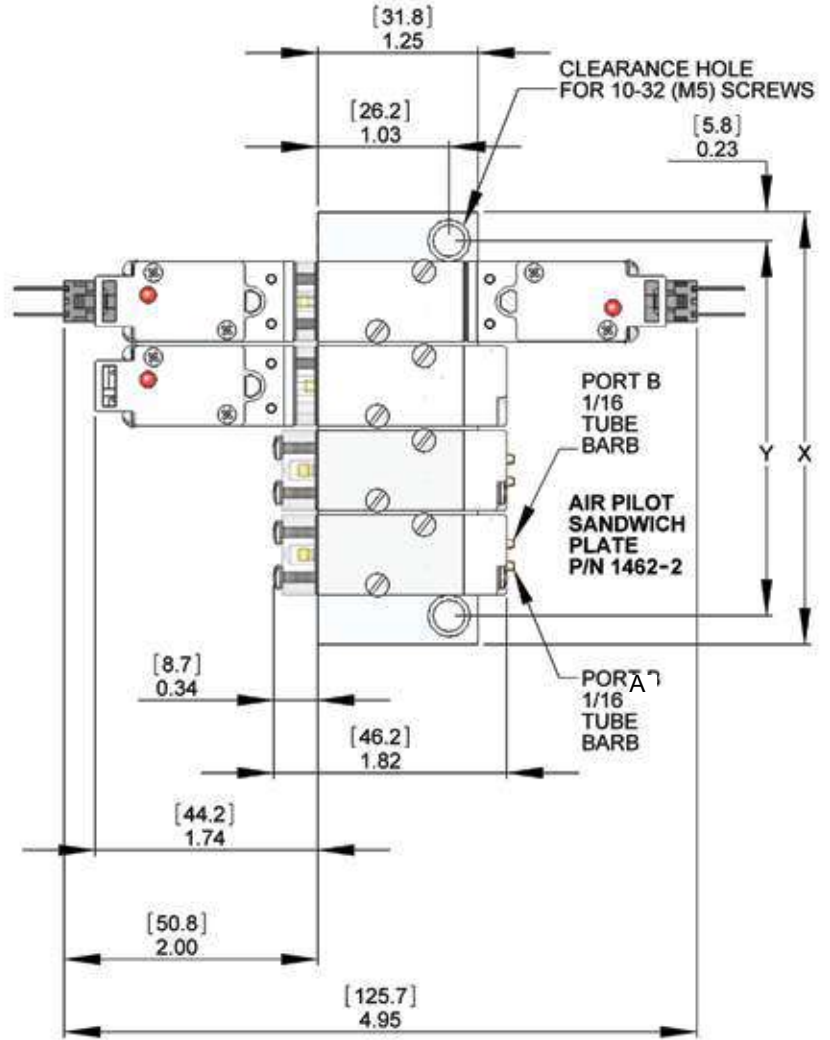
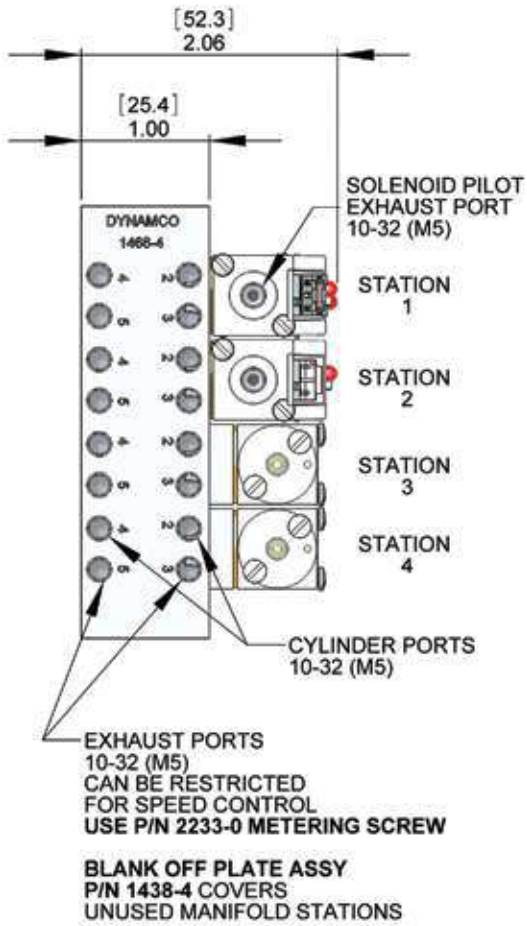

DASH 2 MANIFOLD 1/8 NPT SUPPLY			
P/N	Number of Stations	"X"	"Y"
1466-2	2	2.06 (52.3)	1.61 (40.9)
1466-4	4	3.38 (85.9)	2.93 (74.4)
1466-6	6	4.70 (119.4)	4.25 (108.0)
1466-8	8	6.02 (152.9)	5.57 (141.5)
1466-0	10	7.34 (186.4)	6.89 (175.0)

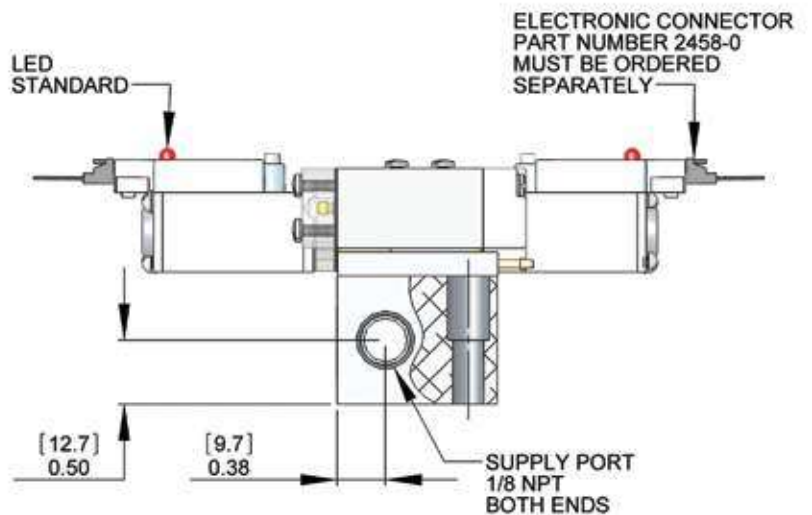



Dash 3 Valves

DASH 3 PILOT OPERATED SOLENOID VALVE QUALITY DESIGN FEATURES

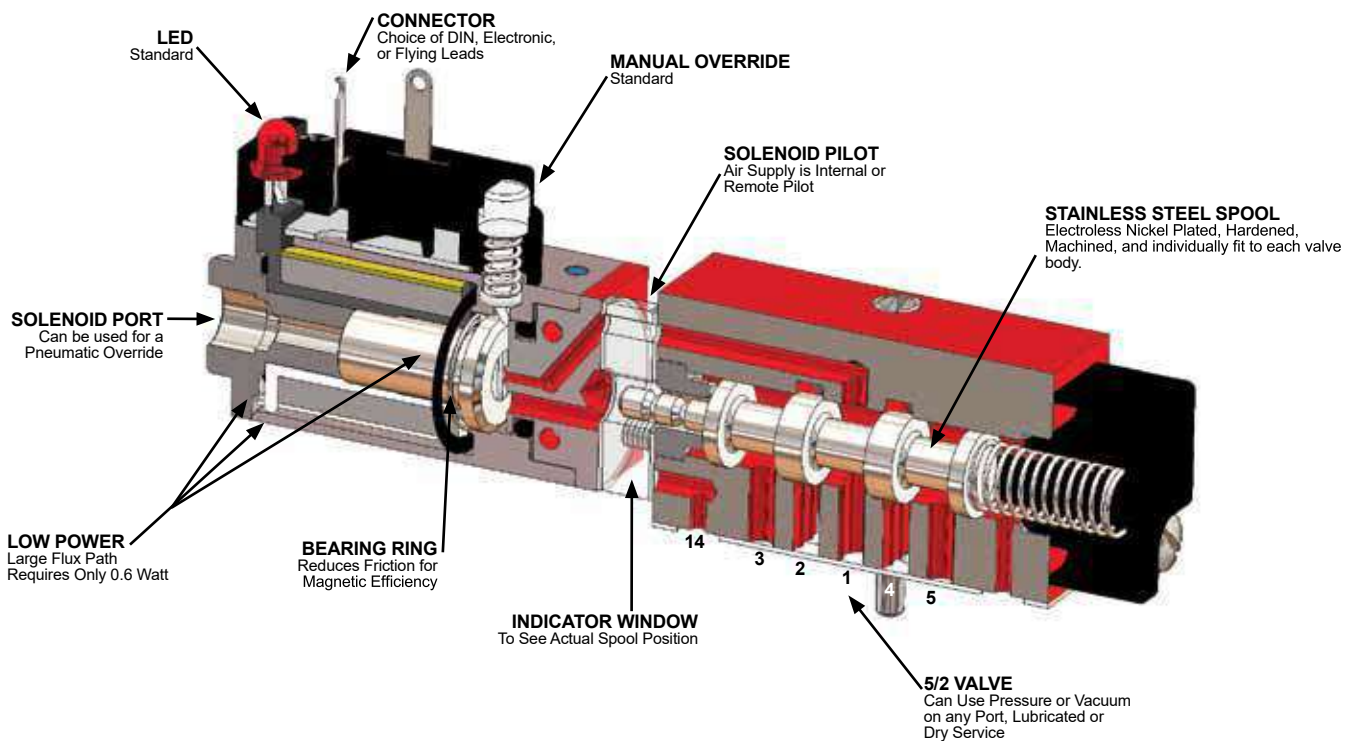

DASH 1 SOLENOID OPERATOR

Solenoid Life 100,000,000 Cycles

HIGH FLOW Cv=.40

31 SCFM (886 LPM) .200 Inch (5.0 mm) Dia.
(See Flow Curves Page 31)

MANIFOLDS

For Mounting and Connecting Multiple Valves

MINATURE SIZE

.75 in. (19 mm) Wide

BASEPLATES

Choice of Side and Bottom Ports

FAST RESPONSE

.004 - .007 Sec. to Shift

Dash 3 Valves



D3532KLO DASH 3 SINGLE POS SOLENOID ELECTRONIC
 2594-0 1/8 NPT Side Ported Base
 2458-0 Removable Electronic Connector

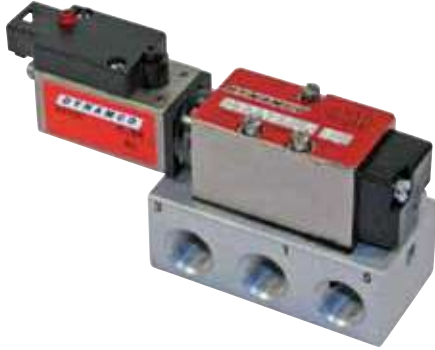

D3533KLO DASH 3 POS DIN
 2803-0 1/8 BSPP Base
 2270-0 DIN Connector



VALVE BODY AND SPOOL DESIGN

There are no moving seals in the DASH 3 valve! The DASH 3 is a metal to metal lapped spool valve. Traditional metal to metal valves can be unforgiving and require extremely fine filtration. Dynamco's design of using dissimilar metals of different hardnesses eliminates the need. DYNAMCO controls the clearances between the body and spool by individually match fitting each spool and body to achieve a proper floating air bearing. The clearance has a narrow range that every valve must achieve. The thermal expansion coefficients of the body and spool are the same so the clearance stays the same over a wide range of conditions.

MINIATURE SIZE AND HIGH FLOW

DASH 3 valves are .75 inches (19mm) wide and yet have a C_v of .40 that will flow over 31 SCFM (900 Liters/Min.). See Flow Curves on page 31.

SPEED

DASH 3 valves are extremely fast. The pilot operated solenoid DASH 3 can shift in 4 to 7 milliseconds. The higher the pressure the faster the shift time.

REPEATABILITY

In DYNAMCO's DASH 3 valves virtually all friction has been eliminated. The only force on the spool is the spring and the air pressure from the solenoid pilot. Valves with moving seals not only have friction, but friction changes with lubrication, moisture, temperature, etc. DYNAMCO valves respond the same regardless of ambient conditions.

LOW ELECTRICAL POWER REQUIREMENTS

0.6 watt power consumption of the pilot operated solenoid allows DASH 3 valves to be controlled by almost any electronic control.

LIFE

The design life of DYNAMCO's DASH 3 POS valves is well in excess of 100 million cycles. This performance has been thoroughly proven in laboratory tests and field performance.

LED INDICATOR

DASH 3 valves have a red LED as a standard feature.
Note: Take care to connect the positive wire (red) to the #1 (positive) terminal and the negative wire (black) to the #2 (negative) terminal when attaching the signal wires to the connector. If the polarity is reversed, the valve will work, but the LED will not illuminate. If the LED appears too dim, check the voltage level supplied to the solenoid. It is probably below the minimum rated level.

SPOOL INDICATOR WINDOW

The spool indicator window shows the physical position of the spool. Having both the LED indicator and indicator window is invaluable in setting up and troubleshooting machines.

SOLENOID PILOT AIR

The DASH 3 valve can be ordered with a main supply connection or a remote pilot connection. Also, the configuration can be switched in the field without any additional parts.

PNEUMATIC OVERRIDE

The solenoid operator port can be used for a pneumatic override. A 3 way (3/2) signal will shift the valve spool against the return spring (or detent in a double solenoid).

QUALITY

Quality must be present in both design and manufacturing. Our strict standards ensure the DASH 3 valve is the highest quality design available. **We are an ISO 9001: 2008 certified company.**

DYNAMCO manufactures practically all components for DASH 3 in its own manufacturing facility. Every DASH 3 is given a complete battery of tests at various stages of manufacture. DYNAMCO's care and attention to detail mean you receive a thoroughly proven product when it is finally given the DYNAMCO name and packed for shipment.



Dash 3 Valves

DASH 3 PILOT OPERATED SOLENOID MAIN SUPPLY

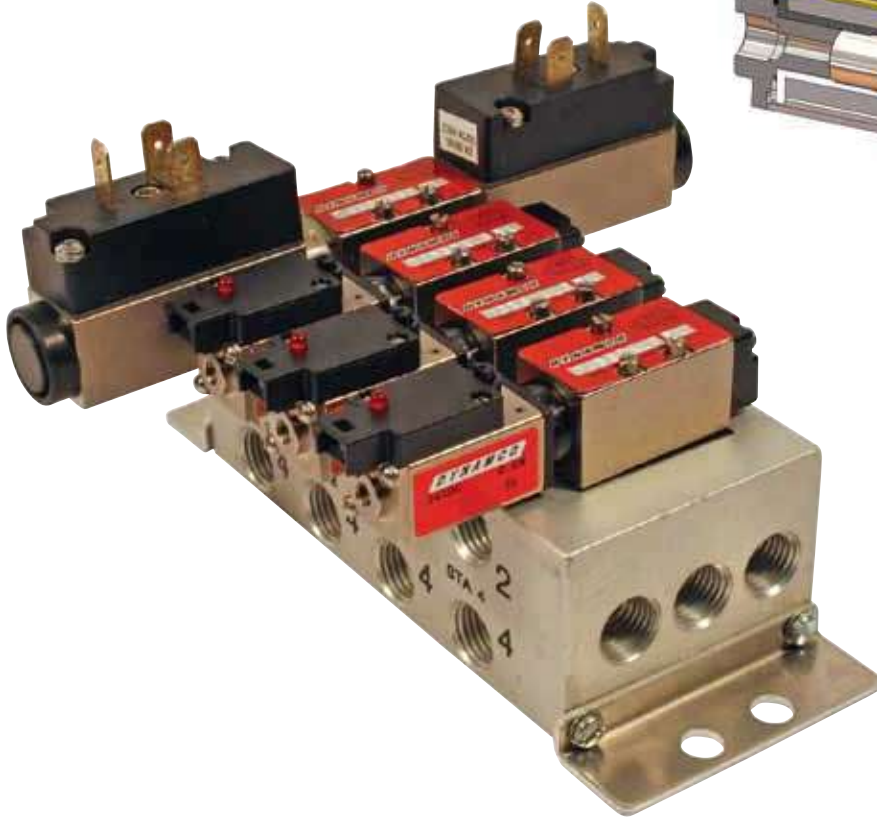
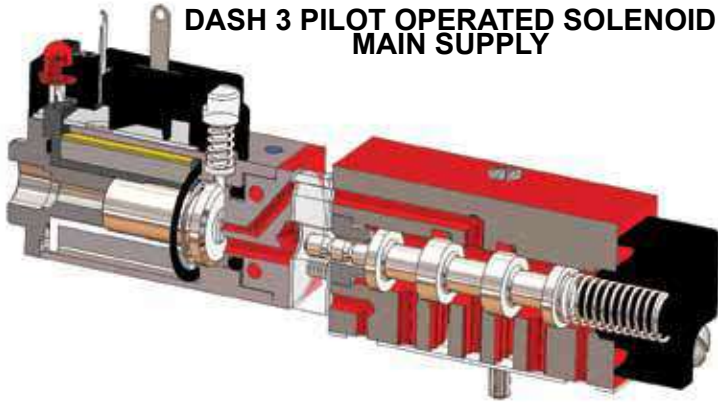

M03N2S04 MANIFOLD 4 STATION

3 Valves	D3532KLO	Dash 3	Single	POS
1 Valve	D3456560	Dash 3	Double	DOS

ELECTRICAL SPECIFICATIONS

Voltage (Volts)	Power (Watts)	Resistance (OHMS)	Current (Amps)
5*	0.6	45	.111
12*	0.6	260	.050
24*	0.6	1100	.027
115*	2.5	5500	.021

*The voltage can be AC (50/60 Hz) or DC. For AC operation use AC lead wires (described on page 4) and the proper voltage DC DASH 3 POS valve. Voltage tolerance is +15% -10% of rated. Solenoids are rated for continuous duty.

TEMPERATURE RANGE

For DASH 3 POS Models below 1 watt:
0° to 150°F (-18° to 65°C)

For DASH 3 POS Models above 1 watt:
0° to 122°F (-18° to 50°C)

MOUNTING

Generally DASH 3 POS valves may be mounted in any orientation. DYNAMCO recommends mounting DASH 3 valve spools horizontally if vibration is present.

MATERIALS

Valve BodyElectroless Nickel Plated S.S.
 Valve Spool Hardened Stainless Steel
 Springs Stainless Steel
 SealsBuna N and Polyurethane
 Indicator WindowAcrylic
 Spring Housing..... Delrin
 Solenoid Adapter Plate Anodized Aluminum
 Solenoid Housing/Pole Piece Plated Stainless Steel
 ArmatureProprietary
 Coil Form..... Ryton™ R4

PRESSURE RANGE

Spool Valvevacuum to 100 psi (6.9 Bar)
 Min. Std. Solenoid Pilot Press20 psi (1.4 Bar)
 For lower pilot pressure models, please contact DYNAMCO.

SERVICE, FILTRATION AND LUBRICATION

DASH 3 valves are designed for service on air and inert gasses. DYNAMCO recommends 5 micron filtration. Lubrication is not required.

Dash 3 Valves



DASH 3 POS MODEL NUMBERING SYSTEM

EXAMPLE: **D3 6 33 33 0**

VALVE SERIES

Dash 3 Valve D3

VALVE TYPE

Single POS - Connected to Main Supply 5
 Double POS - Connected to Main Supply 6
 Single POS - Connected to Pilot Supply 7
 Double POS - Connected to Pilot Supply 8

ACTUATOR "14" END

(Voltage tolerance +15% -10%)

5 VDC 0.6 Watt Electronic 12
 5 VDC 0.6 Watt DIN 13
 12 VDC 0.6 Watt Electronic 22
 12 VDC 0.6 Watt DIN 23
 24 VDC 0.6 Watt Electronic 32
 24 VDC 0.6 Watt DIN 33
 115 VDC 2.5 Watt Electronic 52
 115 VDC 2.5 Watt DIN 53
 5 VDC 0.6 Watt Elec Conn w/Diode A2
 5 VDC 0.6 Watt DIN Conn w/Diode A3
 12 VDC 0.6 Watt Elec Conn w/Diode B2
 12 VDC 0.6 Watt DIN Conn w/Diode B3
 24 VDC 0.6 Watt Elec Conn w/Diode C2
 24 VDC 0.6 Watt DIN Conn w/Diode C3
 No Solenoid - Adapter Plate Only XX

BASE PLATE OPTION

Without Base Plate 0
 Bottom Ported 1/8 NPT E
 Side Ported 1/8 NPT F
 Bottom Ported 1/4 NPT B03N2B 3
 Side Ported 1/4 NPT B03N2S 4
 Bottom Ported 1/8 BSPP (G 1/8) 2803-0 G
 Side Ported 1/8 BSPP (G 1/8) 2802-0 H
 Bottom Ported 1/4 BSPP (G 1/4) B03B2B C
 Side Ported 1/4 BSPP (G 1/4) B03B2S D

ACTUATOR "12" END

(Voltage tolerance +15% -10%)

5 VDC 0.6 Watt Electronic 12
 5 VDC 0.6 Watt DIN 13
 12 VDC 0.6 Watt Electronic 22
 12 VDC 0.6 Watt DIN 23
 24 VDC 0.6 Watt Electronic 32
 24 VDC 0.6 Watt DIN 33
 115 VDC 2.5 Watt Electronic 52
 115 VDC 2.5 Watt DIN 53
 5 VDC 0.6 Watt Elec Conn w/Diode A2
 5 VDC 0.6 Watt DIN Conn w/Diode A3
 12 VDC 0.6 Watt Elec Conn w/Diode B2
 12 VDC 0.6 Watt DIN Conn w/Diode B3
 24 VDC 0.6 Watt Elec Conn w/Diode C2
 24 VDC 0.6 Watt DIN Conn w/Diode C3

Spring Return - Standard 20 psi* KL
 No Solenoid - Adapter Plate Only XX

*lower pressure models may be available. Please consult DYNAMCO for more information.

- NOTES:**
1. Removable connectors and lead wires must be ordered separately. See page 4.
 2. All voltages can be used on either AC or DC electrical service by ordering the proper AC or DC lead wires. See page 4.
 3. Note: Flying Leads are also available. For more information, please consult Dynamco.

0.200 in (5.0) Orifice

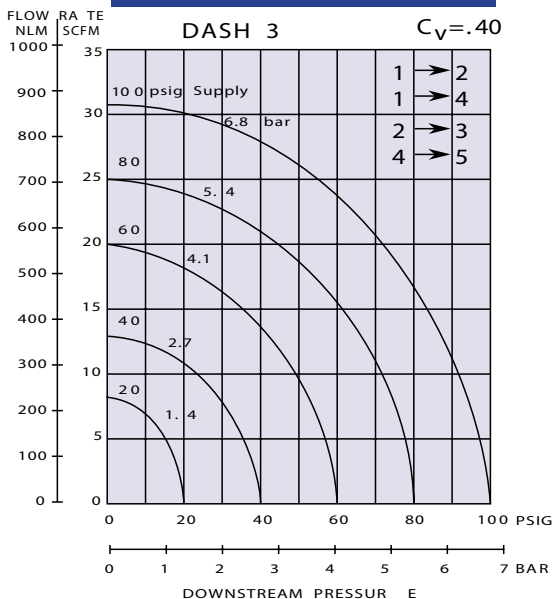

DASH 3 POS VALVE SYMBOLS

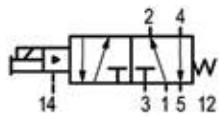

SINGLE SOLENOID
Remote Pilot Supply

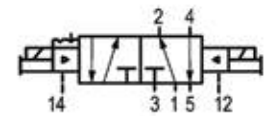

DOUBLE SOLENOID
Remote Pilot Supply

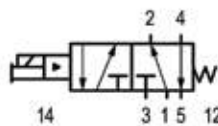

SINGLE SOLENOID
Main Supply

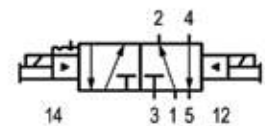

DOUBLE SOLENOID
Main Supply



Dash 3 Valves

DASH 3 DIRECT OPERATED SOLENOID VALVE QUALITY DESIGN FEATURES

NO PILOT AIR REQUIRED!

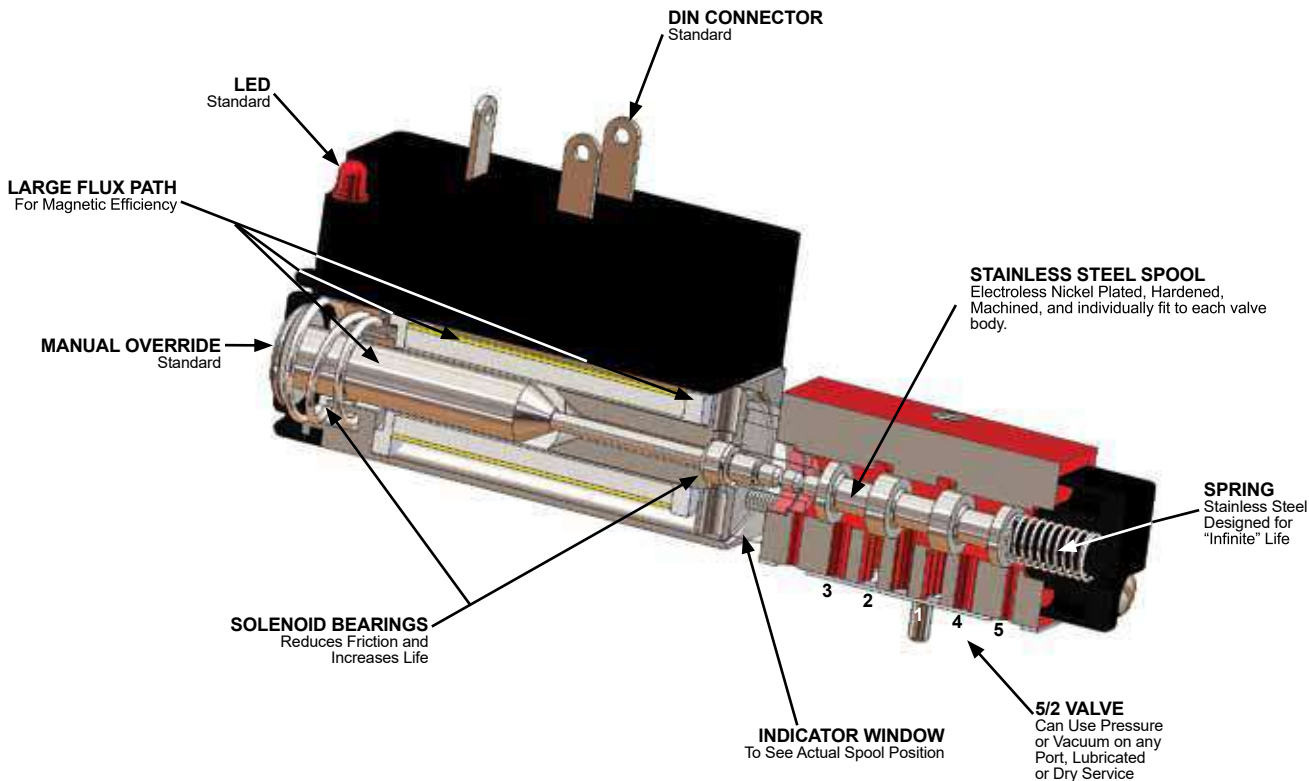

DOS SOLENOID
Requires **NO** Pilot Air
Life 50,000,000 Cycles

HIGH FLOW $C_v=0.40$
31 SCFM (886 LPM) .200 Inch (5.0 mm) Dia.
(See Flow Curves Page 31)

MANIFOLDS
For Mounting and Connecting
Multiple Valves

MINATURE SIZE
.75 in. (19 mm) Wide

BASEPLATES
Choice of Side and Bottom Ports

FAST RESPONSE
.003 - .006 Sec. to Shift

Please note DYNAMCO DASH-3 Direct Operated Solenoid (DOS) Valves are not UL listed.

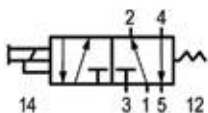

SINGLE SOLENOID
Spring Return

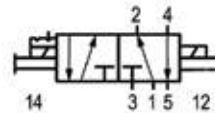

DOUBLE SOLENOID
Detented

Dash 3 Valves



D3356GL0
DASH 3 SINGLE DOS
SOLENOID
B03N2S 1/4 NPT Side Ported Base

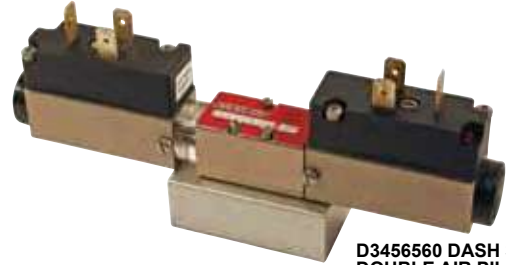

D3456560 DASH 3
DOUBLE AIR PILOTED
B03B2B 1/4 BSPP Bottom Ported Base

DASH 3 DOS MODEL NUMBERING SYSTEM

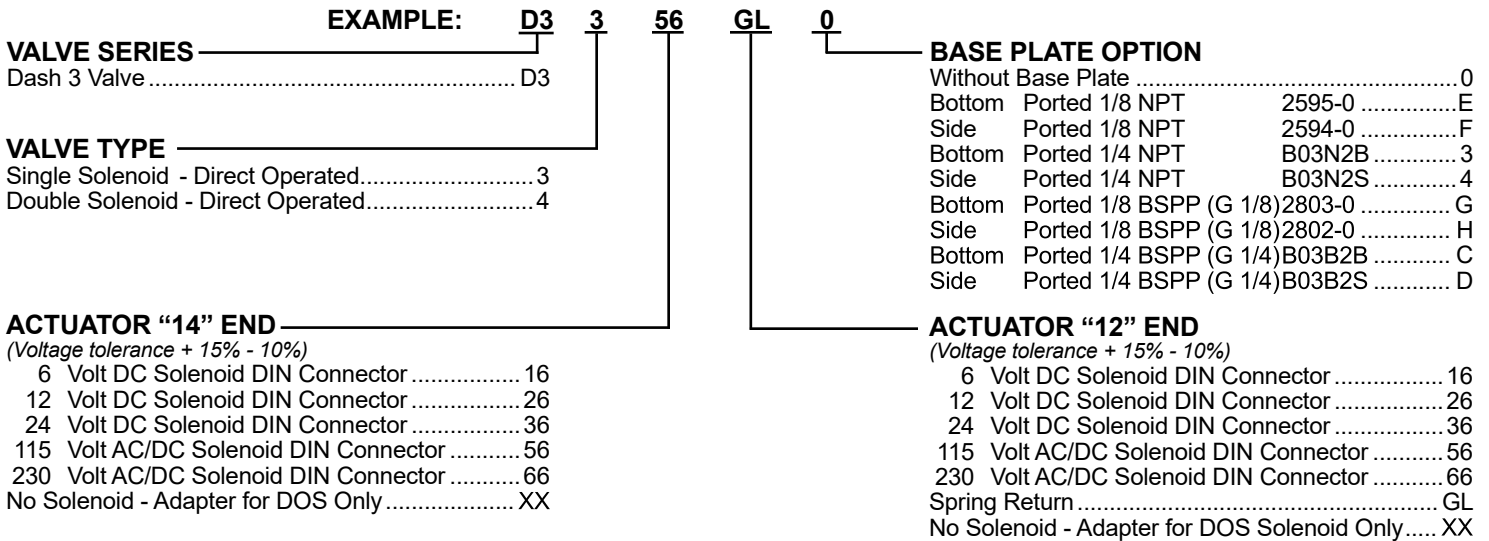

- NOTES:**
1. Removable connector 2285-0 must be ordered separately. See page 36.
 2. Fast-on type connectors are suitable for use with DIN connector terminals.
 3. For 24 volt AC/DC and 48 volt AC/DC - order valves without solenoids and order replacement solenoid operators listed below.
 4. Please note DYNAMCO DASH-3 Direct Operated Solenoid (DOS) Valves are not UL listed.

ELECTRICAL SPECIFICATIONS			
Voltage (Volts)	Power (Watts)	Resistance (OHMS)	Current (Amps)
6 DC	7	5	1.20
12 DC	7	20	.60
24 DC	7	83	.29
24 AC/DC	7	83	.29
48 AC/DC	7	265	.18
115 AC/DC*	7	1900	.06
230 AC/DC*	7	8400	.03

* The voltage can be AC (50/60 Hz) or DC. Voltage tolerance is +15% -10% of rated.

TEMPERATURE RANGE

0° to 122°F (-18° to 50°C)

MOUNTING

DASH 3 DOS valves **MUST BE** mounted with valve spools horizontal.

MATERIALS

Valve Body Electroless Nickel Plated S.S.
 Valve Spool Hardened Stainless Steel
 Springs Stainless Steel
 Seals Buna N and Polyurethane
 Indicator Window Acrylic
 Spring Housing Delrin
 Solenoid Adapter Zinc Plated Steel
 Solenoid Housing Nickel Plated Steel
 Armature Proprietary
 Solenoid Connector Coil Form Rytan™ R4

PRESSURE RANGE

Spool Valve 0 to 100 psi (6.9 Bar)
 Since the DASH 3 DOS is a Direct Solenoid, **NO Solenoid Pilot Pressure is Required!**

SERVICE, FILTRATION AND LUBRICATION

DASH 3 valves are designed for service on air and inert gasses. DYNAMCO recommends 5 micron filtration. Lubrication is not required.



Dash 3 Valves



D30D0A00 DASH 3 DOUBLE AIR PILOTED
2802-0 1/8 BSPP Side Ported Base



D30S0K00 DASH 3 AIR PILOTED SPRING RETURN
2595-0 1/8 NPT Bottom Ported Base

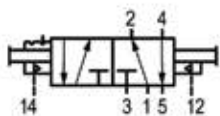

DOUBLE AIR PILOT DETENTED

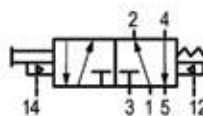

AIR PILOT SPRING RETURN

DASH 3 AIR PILOT MODEL NUMBERING SYSTEM

EXAMPLE: **D30SMK0 0**

VALVE SERIES

Dash 3 Air Pilot Operated Spring Return.....	D30S0K0
Dash 3 Air Pilot Operated Spring Return with Manual Override	D30SMK0
Dash 3 Double Air Pilot Detented	D30D0A0
Dash 3 Double Air Pilot Detented with Manual Overrides.....	D30DMAM

BASE PLATE OPTION

Without Base Plate	0	
Bottom Ported 1/8 NPT	2595-0	E
Side Ported 1/8 NPT	2594-0	F
Bottom Ported 1/4 NPT	B03N2B	3
Side Ported 1/4 NPT	B03N2S	4
Bottom Ported 1/8 BSPP (G 1/8)	2803-0	G
Side Ported 1/8 BSPP (G 1/8)	2802-0	H
Bottom Ported 1/4 BSPP (G 1/4)	B03B2B	C
Side Ported 1/4 BSPP (G 1/4)	B03B2S	D

MATERIALS

Valve Body	Electroless Nickel Plated S.S.
Valve Spool	Hardened Stainless Steel
Springs	Stainless Steel
Seals	Buna N and Polyurethane
Indicator Window	Acrylic
Spring Housing.....	Delrin

PRESSURE RANGE

Spool Valvevacuum to 100 psi (6.9 Bar)
 Minimum Standard Pilot Press20 psi (1.4 Bar)
 For lower pressure pilot models, please contact DYNAMCO.

SERVICE, FILTRATION AND LUBRICATION

DASH 3 valves are designed for service on air and inert gasses. DYNAMCO recommends 5 micron filtration. Lubrication is not required.

TEMPERATURE RANGE

0° to 200°F (-18° to 93°C)

MOUNTING

Generally DASH 3 air piloted valves may be mounted in any orientation. DYNAMCO recommends mounting valve spools horizontally if vibration is present.

Dash 3 Valves



DASH 3 VALVE FOOTPRINT

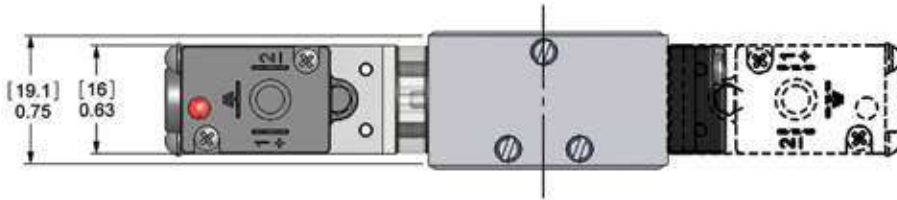
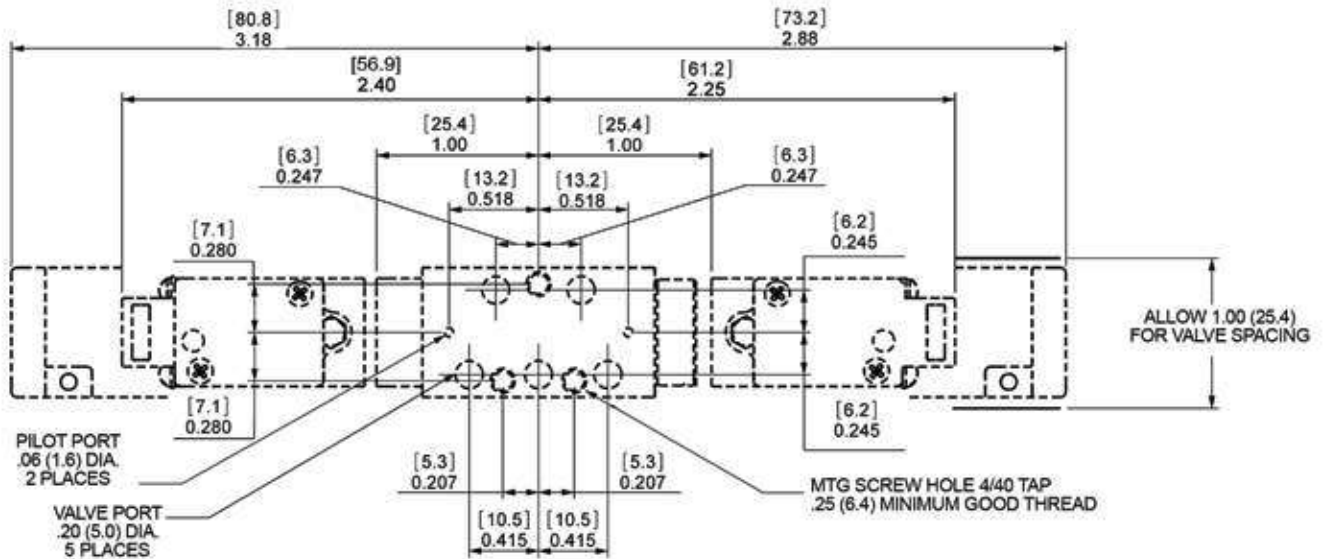

DASH 3 POS VALVE WITH DIN CONNECTOR

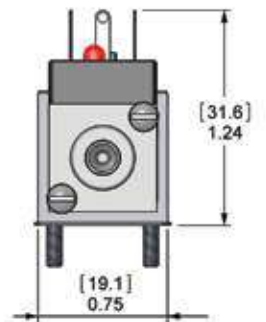
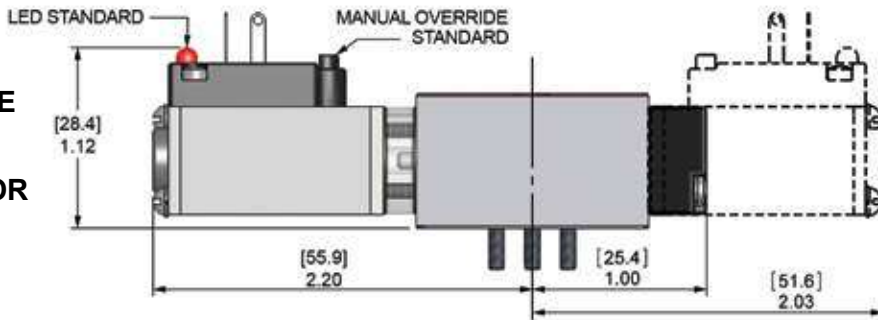

DASH 3 POS VALVE WITH ELECTRONIC CONNECTOR

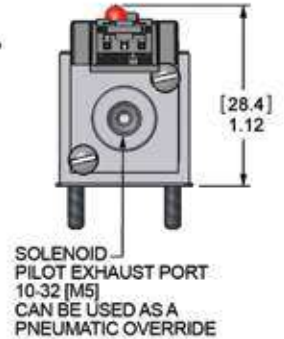
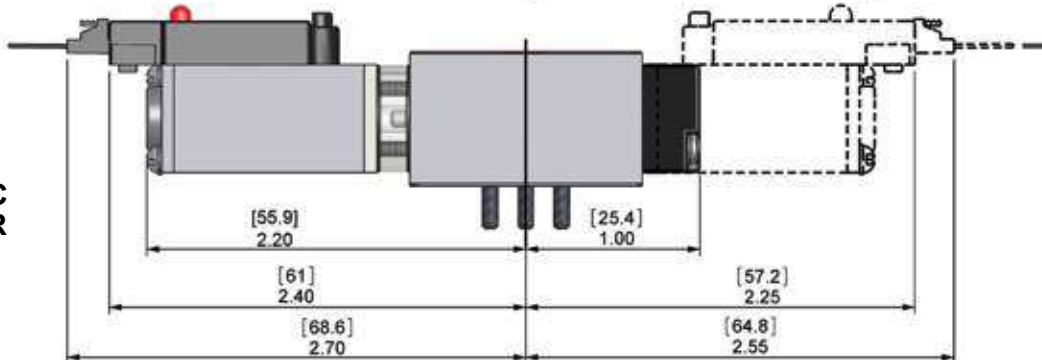

Dimensions shown in inches [mm]



Dash 3 Valves

DASH 3 DOS DIN CONNECTORS

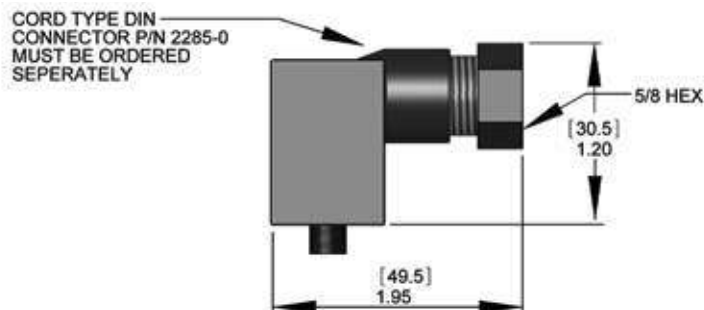

DASH 3 DIRECT OPERATED SOLENOID VALVES

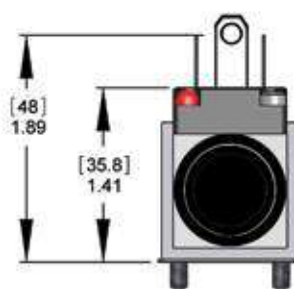
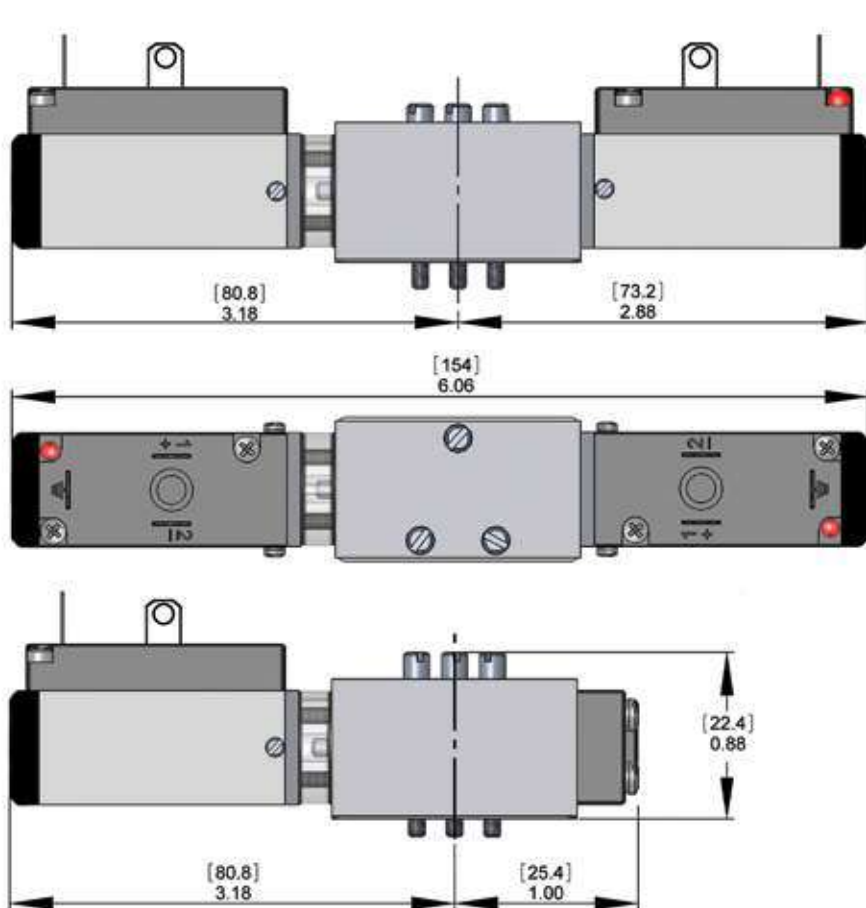

REPLACEMENT (DOS) DIRECT OPER SOLENOIDS	
Voltage	Part P/N
6 VDC	2373-0
12 VDC	2374-0
24 VDC	2375-0
24 VAC/DC	2375-2
48 VAC/DC	2375-3
115 VAC/DC	2376-0
230 VAC/DC	2377-0

Dimensions shown in inches [mm]

DASH 3 AIR PILOT OPERATED VALVES

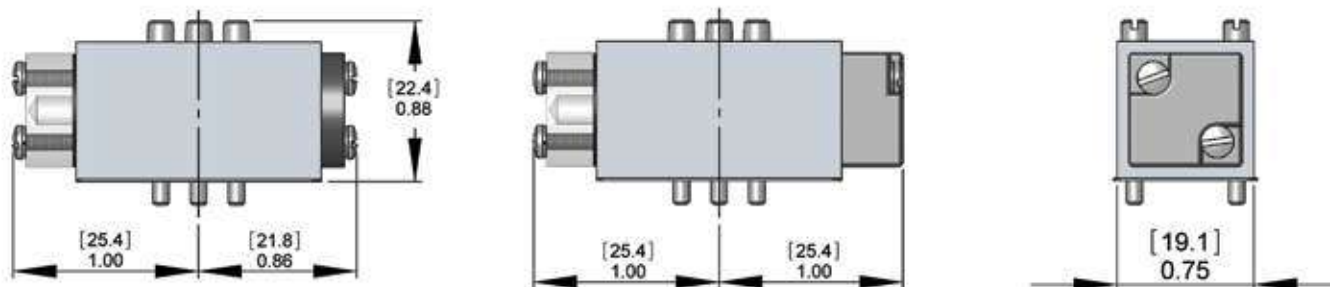

Dash 3 Baseplates

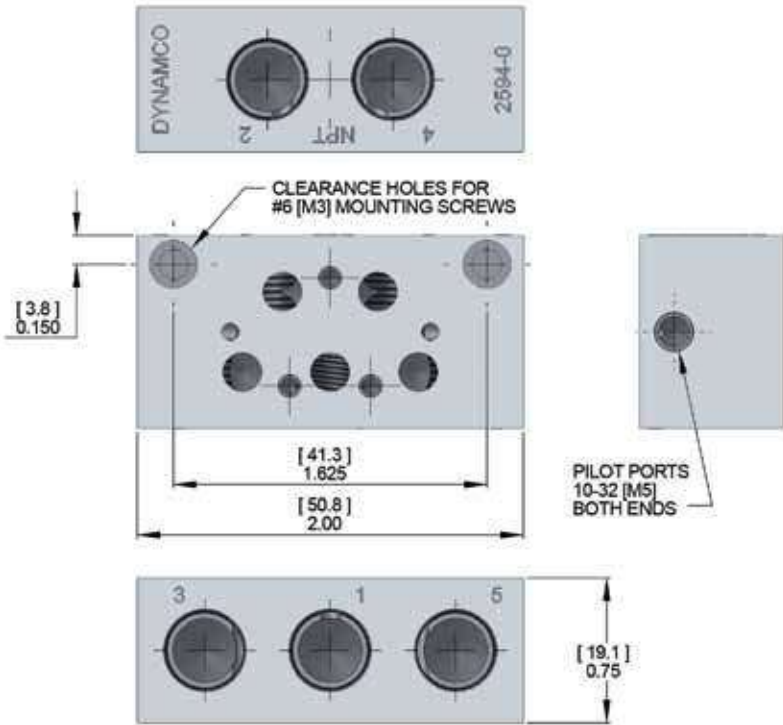

DASH 3 1/8 PIPE SIDE PORTED
1/8 NPT 2594-0
1/8 BSPP 2802-0

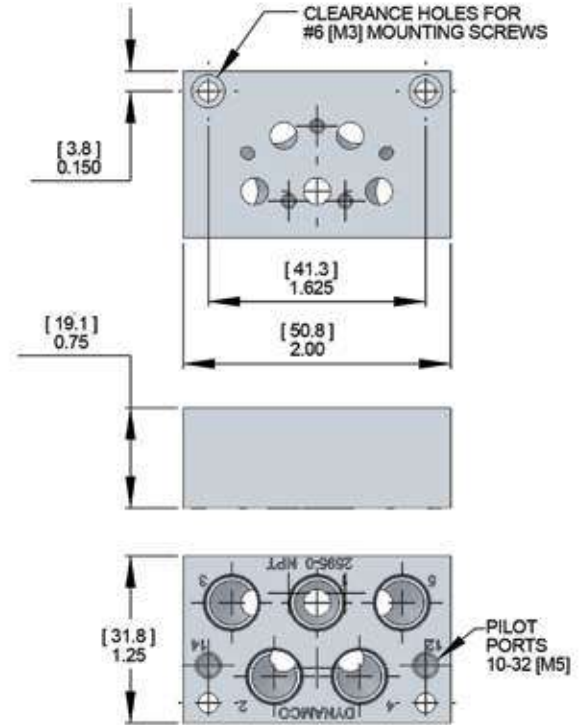

DASH 3 1/8 PIPE BOTTOM PORTED
1/8 NPT 2595-0
1/8 BSPP 2803-0

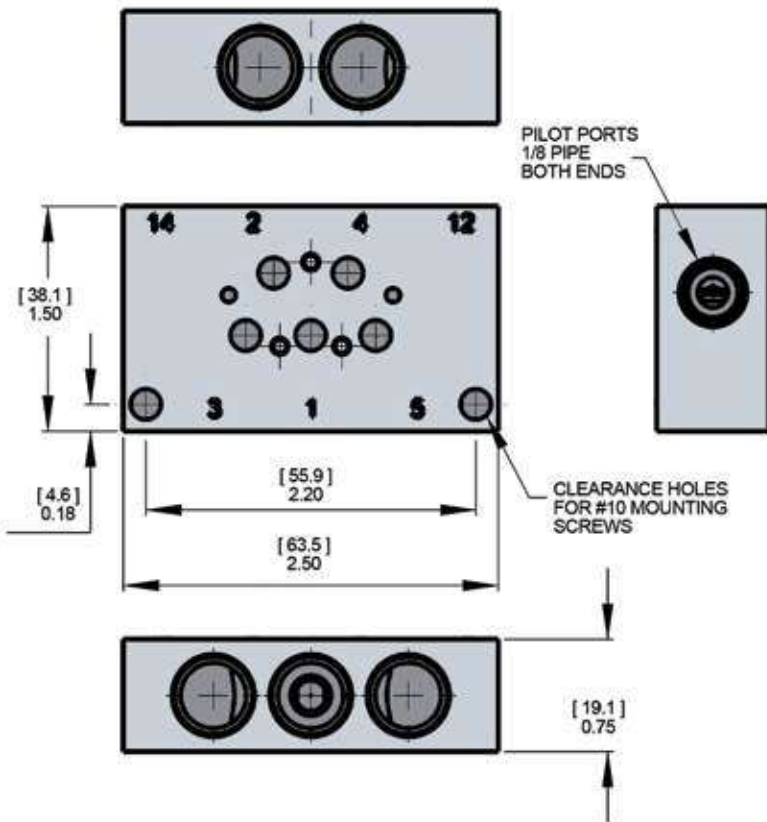

DASH 3 1/4 PIPE SIDE PORTED
1/4 NPT B03N2S
1/4 BSPP B03B2S

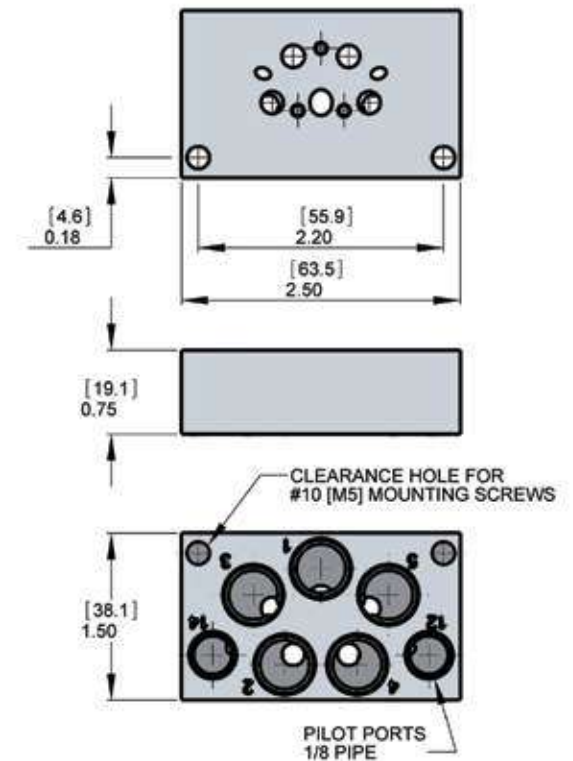

DASH 3 1/4 PIPE BOTTOM PORTED
1/4 NPT B03N2B
1/4 BSPP B03B2B

Dimensions shown in inches [mm]



Dash 3 Manifolds



M03N2S04 Manifold 4 Station 1/4 NPT

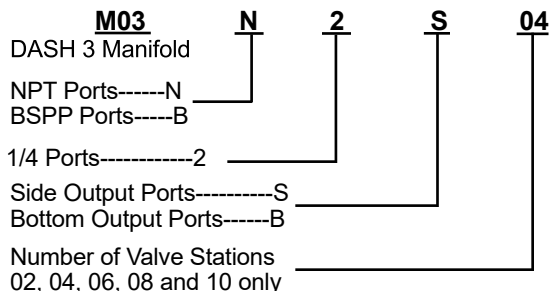

DASH 3 VALVE MANIFOLDS

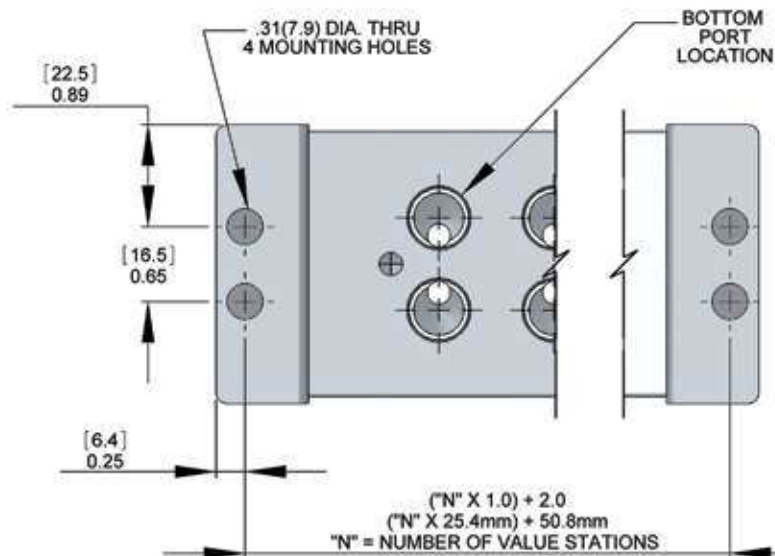
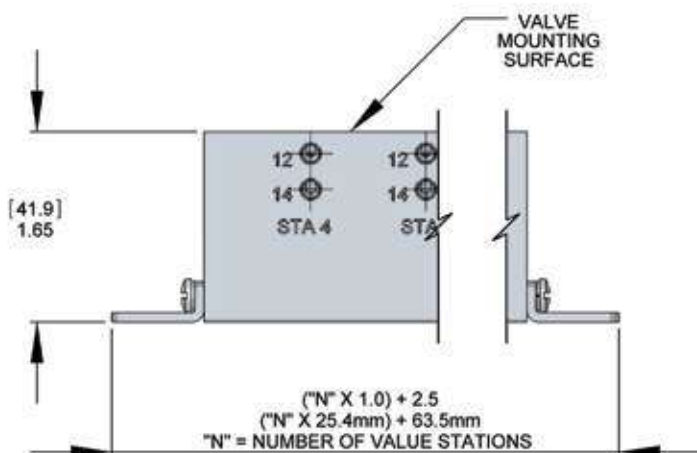
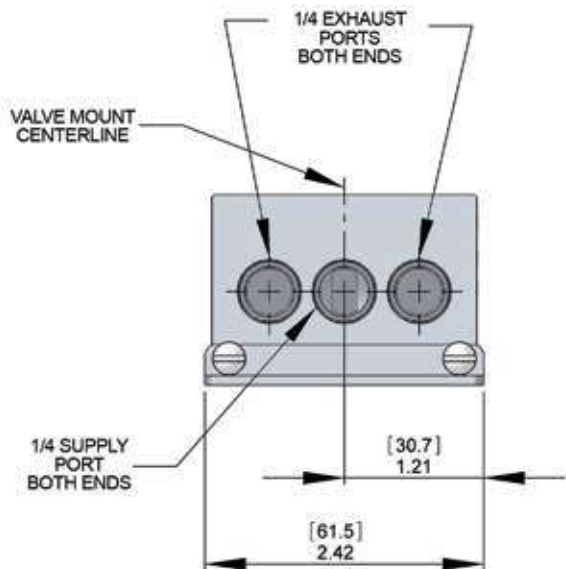

Stackable Manifolds



This manifold system, comprised of headers, sections, etc. is a flexible and versatile set of building blocks. Sections are joined with threaded rods and are sealed with O-rings. Features include:

- Modular construction using expandable building blocks
- Can configure for special requirements
- Can modify for design changes
- Can easily be changed in the field
- Extremely high flow
- O-ring plate sealing
- NPT or BSPP pipe threads
- Internal gallery block option
- External pressure supply option
- Multiple supply pressures (or vacuum)
- Use combination of DASH valves
- Common or separate exhausts
- Exhausts can be used for speed Control
- Very compact and cost effective

EXAMPLE MANIFOLD STACK STACKABLE 10-32 (M5) BOTTOM PORTED MANIFOLD*

The manifold stack pictured below has one supply gallery and two identical exhaust galleries. Study the type of and number of valves mounted as well as the supply and exhaust galleries. Page 40 shows the parts available in the family.

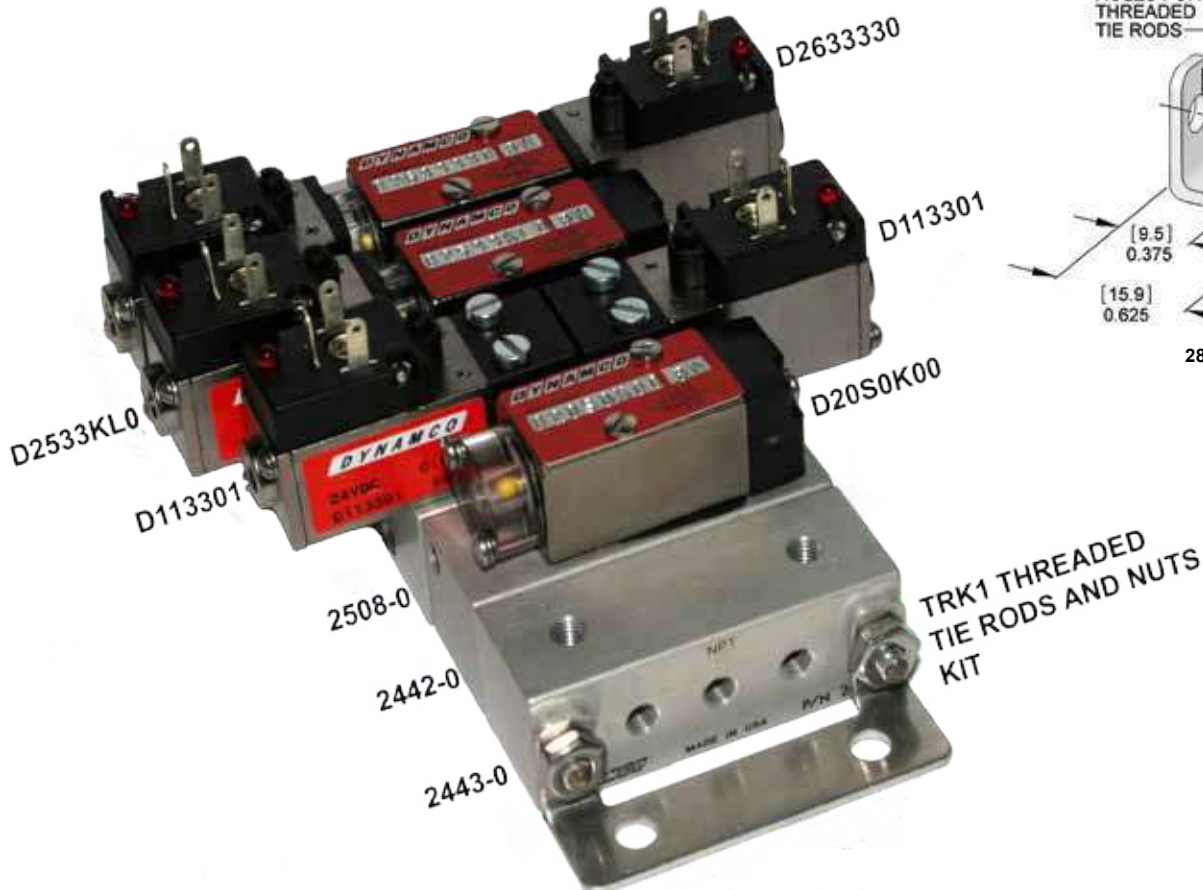

BLANK SECTIONS

“Blank” sections allow you to connect portions of the supply/ exhaust galleries by drilling spot drilled holes to fit your exact requirements.

MOUNTING AND THREADED RODS

Methods of mounting the manifold stack include:

1. Order quantity required P/N 2808-0 Mtg Bracket
2. P/N 2443-0 provides 10-32 (M5) mounting holes on 1.305 (33.1) centers.
3. It may be possible to use available ports (such as pilot ports on a solenoid stack) to mount the stack.

TRK1 Threaded Rod Kits include 2 pieces 12 inch (30 cm) 8-32 threaded rod and 4 pieces 8-32 nuts.

NOTES:

- Part numbers include the necessary O-Rings.
- All ports are 10-32 (M5) unless specified.
- All Cylinder Ports are on the bottom.

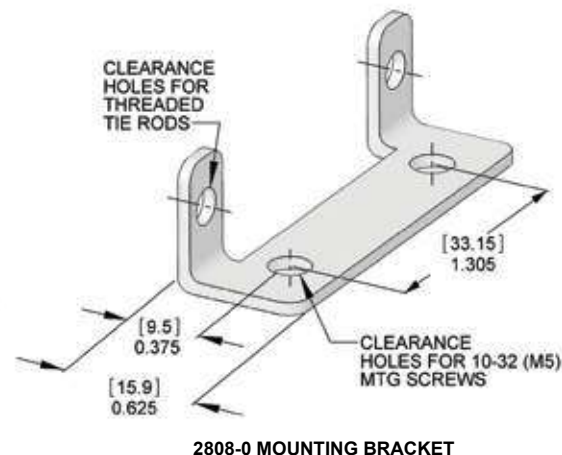

* 10-32 (M5) options available in DASH 1 and DASH 2 only.



Stackable Manifolds

HEADER LEFT END	<p>P/N 2433-0</p> <p>Supply</p> <p>Header and Mounts 1 Valve DASH 2</p> <p>Exhaust</p>	<p>P/N 2443-0</p> <p>Supply</p> <p>Header Only 1/8 NPT</p> <p>Exhaust</p>	<p>P/N 2443-5</p> <p>Supply</p> <p>Header Only 1/8 BSPP G 1/8</p> <p>Exhaust</p>	<p>P/N 2805-0</p> <p>Supply</p> <p>Header and Mounts 2 Valves DASH 1</p> <p>Exhaust</p>
	CENTER SECTION	<p>P/N 2431-0</p> <p>Supply</p> <p>Mounts 1 Valve DASH 2</p> <p>Exhaust</p>	<p>P/N 2442-0</p> <p>Supply</p> <p>Mounts 1 Valve DASH 2 Has 12 & 14 Port Holes in End</p> <p>Exhaust</p>	<p>P/N 2804-0</p> <p>Supply</p> <p>Mounts 1 Valve DASH 2</p> <p>Exhaust</p>
HEADER RIGHT END		<p>P/N 2432-0</p> <p>Supply</p> <p>Header and Mounts 1 Valve DASH 2</p> <p>Exhaust</p>	<p>P/N 2443-0</p> <p>Supply</p> <p>Header Only 1/8 NPT</p> <p>Exhaust</p>	<p>P/N 2443-5</p> <p>Supply</p> <p>Header Only 1/8 BSPP G 1/8</p> <p>Exhaust</p>
	BLANK SECTION	<p>P/N 2434-0</p> <p>Supply</p> <p>Mounts 1 Valve DASH 2 Can Be Drilled In-Field</p> <p>Exhaust</p>	<p>NOTE: All Cylinder Ports are Located on Bottom.</p>	

Stackable Manifolds



1/8" STACKABLE MANIFOLD

This manifold system is a flexible and versatile set of building blocks that can be used for all classes of DYNAMCO DASH series valves. Its modular design generally makes meeting special applications easy. Sealing plates with O-rings separate the modules which are joined together with three tie rods. All module sections are supplied as kits. Each kit comes with a base section, sealing plate, and O-rings. A special gallery block may be used to block off the supply and/or exhaust galleries.

EXAMPLE MANIFOLD STACK

The manifold stack shown on the following page covers a wide variety of options available in this family. The family consists of Headers, Center Modules, Master Modules, External Pressure Supply Modules, Gallery Block Kits and Mounting Brackets.

These parts can be assembled to combine DASH 1, DASH 2 and DASH 3 valves on the same manifold. Manifold assemblies can be side ported, bottom ported, or a combination of both. A Master Module can be used to allow air to supply the gallery only when that valve is energized.

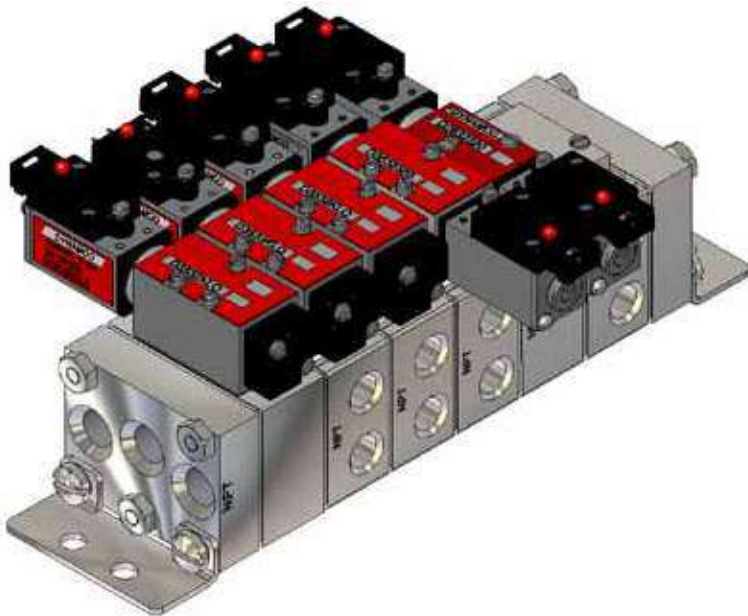

MOUNTING AND THREADED RODS

Each mounting bracket comes with screws and washers for attaching to the header section. Order the actual quantity of mounting brackets needed. Threaded Rod Kits include 3 pieces of 12 in (30 cm) 8-32 threaded rod and 12 pieces 8-32 nuts. See the chart on page 45 for the overall manifold length, mounting hole location, and the approximate lengths to cut the threaded rods.

NOTES

Headers are required on both ends of the manifold. Supply and exhaust gallery ports are 1/4" pipe (NPT or BSPP).

All cylinder ports are 1/8" pipe (NPT or BSPP). A combination of both side and bottom ported modules can be assembled within the same manifold stack.

The Master Module controls the air supply to the module sections downstream of it. Energizing the DASH 3 on the Master Module supplies air to the manifold while de-energizing it exhausts the air. There are no cylinder ports available on the Master Module.

External Supply Modules are available for both DASH 2 and DASH 3 in side ported versions only. These sections are used when more than two different supply pressures are needed. These additional pressures are supplied through the 1/8" pipe port (NPT or BSPP) located on the side of the module opposite the cylinder ports.

A Gallery Block Kit includes a disc which fits inside of a gallery O-ring. When placed inside the proper sealing plate the block isolates the two sides of the gallery. One is needed for dual pressures and two or more are needed for multiple supply pressures.

There is no provision for pneumatic pilot port 12 on this manifold. Therefore, remote pilot solenoid valves and air pilot valves cannot be used on port 12.

Dash 3 DOS solenoid valves cannot be mounted on adjacent stations. (Screws attaching solenoid protrude on the sides.)

Blank-off plate assemblies are available to seal off unused stations. P/N 2550-0 covers DASH 1 stations, P/N 1438-4 for DASH 2 stations, and P/N 2355-0 for DASH 3 stations.

External Pressure Supply Modules used with Gallery Blocks allow provisions for multiple supply pressures.



Stackable Manifolds

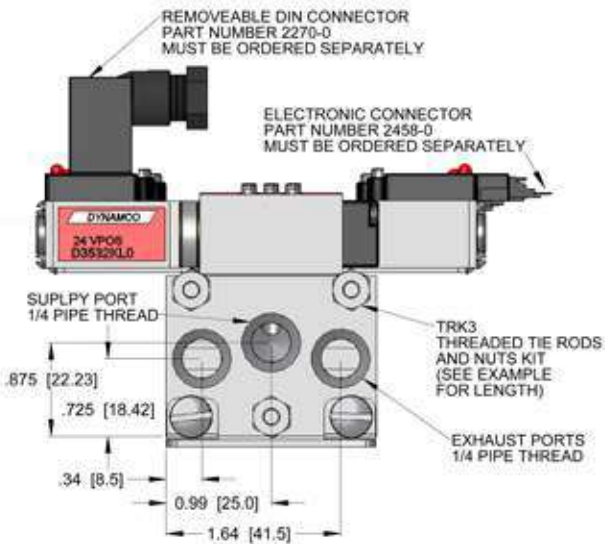
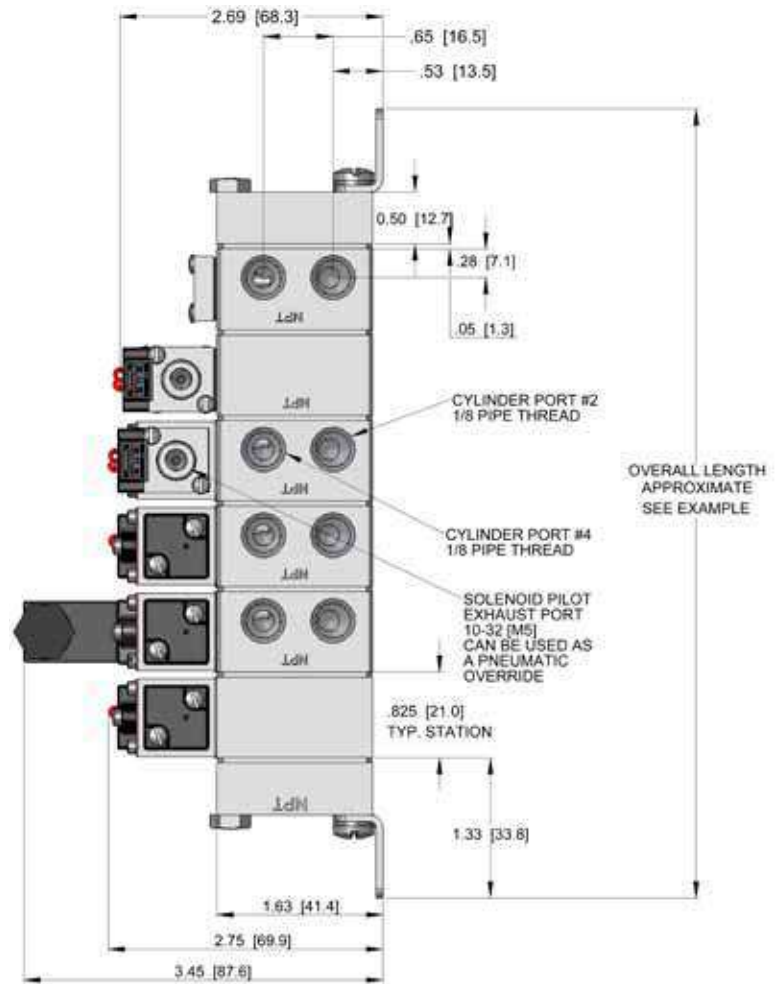
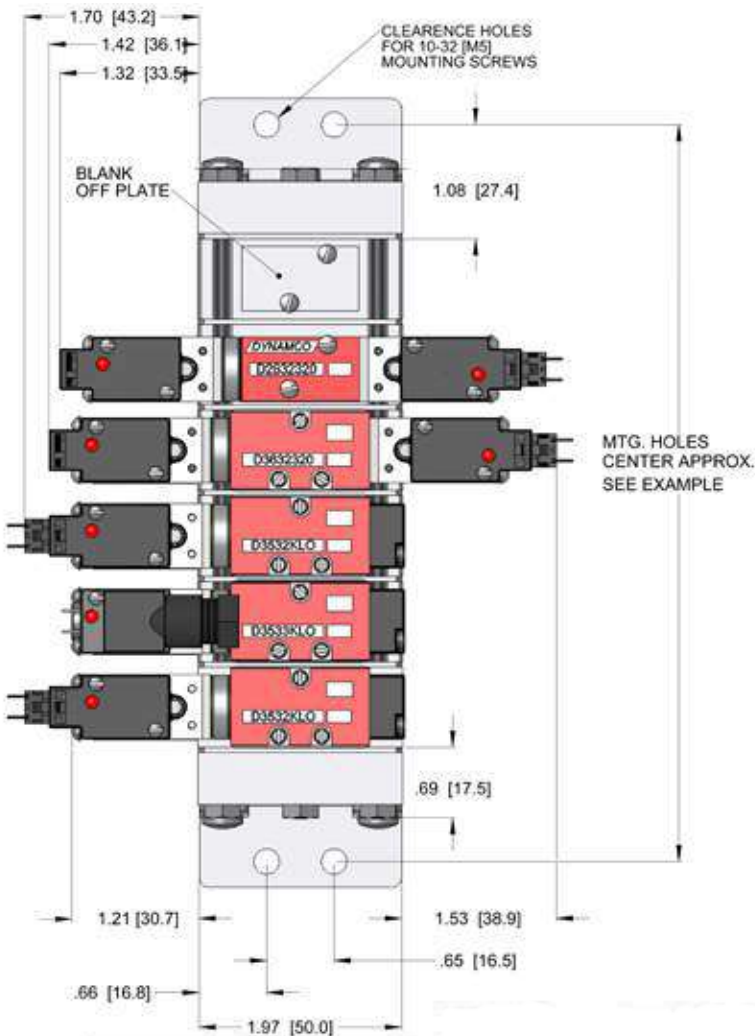

EXAMPLE OF A 6-STATION MANIFOLD

Mounting Holes Centers:

6 stations x .825" + 2.15" with headers & Brackets = 7.10" (6 sta. x [21.0]+[54.6]=[180.6])

Overall Length:

6 sta. x .825" + 2.65" with two headers and brackets = 7.60" (6 sta. x [21.0]+[67.3]=[193.3])

Tie Rod Length:

6 sta. x .825" + 1.38" with two headers and one nut on the end of each rod= 6.33" (6 sta. x [21.0]+[35.0]=[161.0])

Stackable Manifolds



1/8" STACKABLE MANIFOLD PART NUMBER LIST

P/N for NPT Pipe Thread	Description	P/N for BSP Pipe Thread
2877-1	Header (2 Required)	2878-1
3163-1	DASH 1 Side Ports Module	3164-1
2550-0	DASH 1 Blank Station Cover, Gasket, Screws	2550-0
2862-1	DASH 2 Side Ports Module	2863-1
2862-2	DASH 2 Side Ports Module with Port 14 Pilot	N/A
2866-1	DASH 2 Bottom Ports Module	2867-1
2891-1	DASH 2 Side Ports External Pressure Supply*	2892-1
1438-4	DASH 2 Blank Station Cover, Gasket, Screws	1438-4
2876-1	DASH 3 Master Module	2876-1
2876-2	DASH 3 Master Module with Port 14 Pilot	2876-2
2870-1	DASH 3 Side Ports Module	2871-1
2870-2	DASH 3 Side Ports Module with Port 14 Pilot	2871-2
2874-1	DASH 3 Bottom Ports Module	2875-1
2874-2	DASH 3 Bottom Ports Module with Port 14 Pilot	N/A
2895-1	DASH 3 Side Ports External Pressure Supply*	2896-1
2355-0	DASH 3 Blank Station Cover, Gasket, Screws	2355-0
2880-1	Mounting Bracket (1) (753-5 Lock Washer, 824-1 Screw)	2880-1
2882-1	Gallery Block Kit (1 Disc & 1 Ring)	2882-1
TRK3	Threaded Rod and Nuts (For 12 Valve Stack)	TRK3

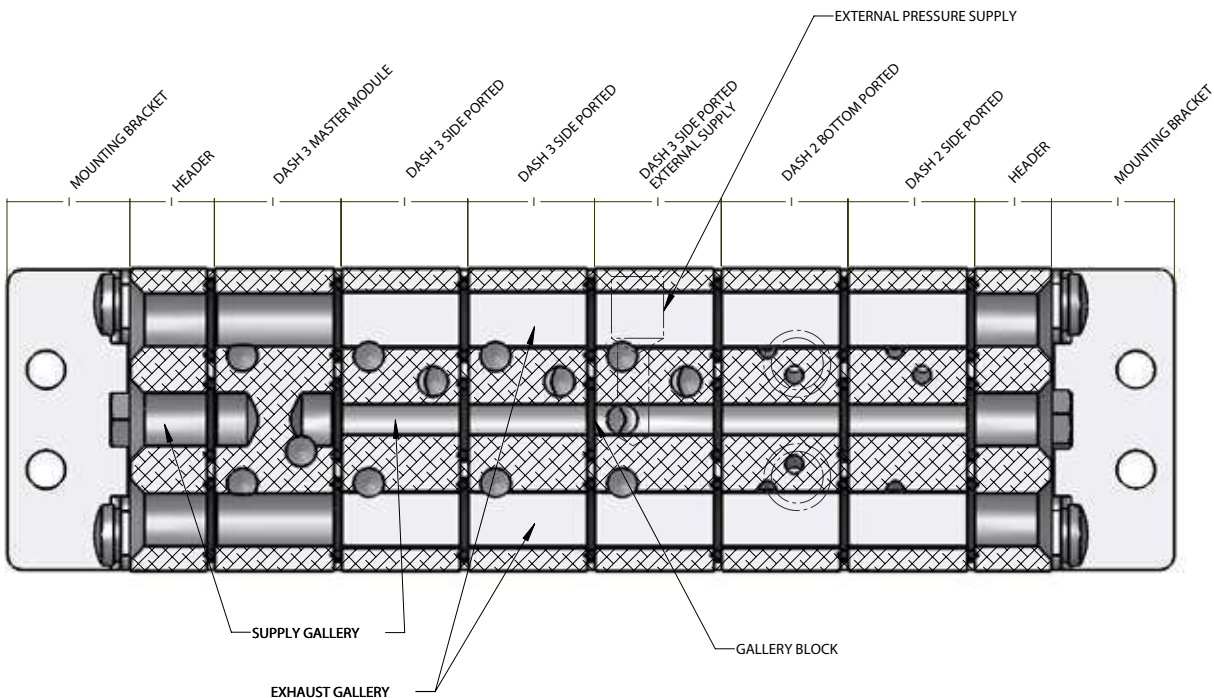



Sandwich Regulator

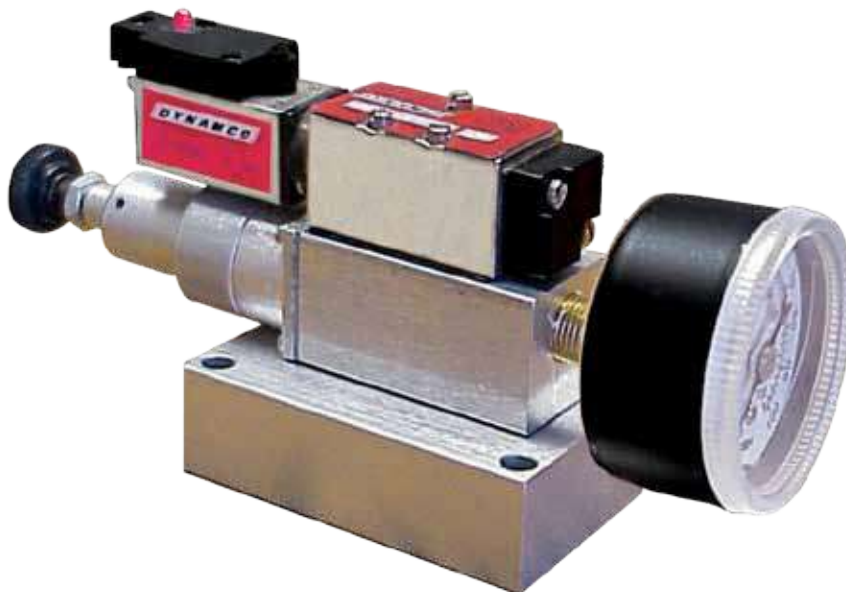

SANDWICH REGULATOR (DASH 3 FAMILY)

The DASH 3 “Sandwich” Regulator allows simplified pressure regulation through the use of a manifold style regulator that mounts directly between a Dynamco DASH 3 valve and any corresponding baseplate or manifold system. The supply air connected to Port 1 of the baseplate / manifold is directed through the regulator before being connected to Port 1 of the valve, allowing a simplified, compact, and robust means of delivering correct line pressure to pneumatic equipment.

The DASH 3 Sandwich regulator will fit any of Dynamco’s DASH 3 baseplates. Because the regulator measures 0.90” in width, the regulator can be mounted in any station of the stackable manifold family as long as there is not a regulator in an adjacent station. If gages (not supplied as standard) are used, users must be aware of the physical envelope of the complete component.

FEATURES

Compact Design
Mounts directly on Dynamco DASH 3 Valves and Manifolds
Ported for Gage

BENEFITS

Reduces pipe work and leaks
Combines several components into a simple manifold

SPECIFICATIONS

Regulator Body.....	Aluminum
Sandwich Body.....	Aluminum
Gaskets.....	Polyurethane
Max Pressure.....	100 psi (0-6.9 bar)
Regulator Output.....	0-100 psi (0-6.9 bar)
Temperature Range.....	0-150° F (-18-66° C)

NOTE: The DASH 3 Sandwich regulator is not suitable for use with Air Pilot Valves since the pilot ports are not connected.

Sandwich Regulator



PART NUMBERS

3165-2 Complete kit as shown. Includes items below.

Qty.	Item	Description
1	3165-0	Regulator
1	3152-1	Sandwich Block w/ long screws & Gaskets
2	1268-1	DASH 3 Gasket
1	441-1	0-100 PSI Gage

3165-1 Same as above, but without gage. Includes items below.

Qty.	Item	Description
1	3165-0	Regulator
1	3152-1	Sandwich Block w/ long screws & Gaskets
2	1268-1	DASH 3 Gasket

Note: Sandwich Block Only is P/N 3152-0.

DIMENSIONS

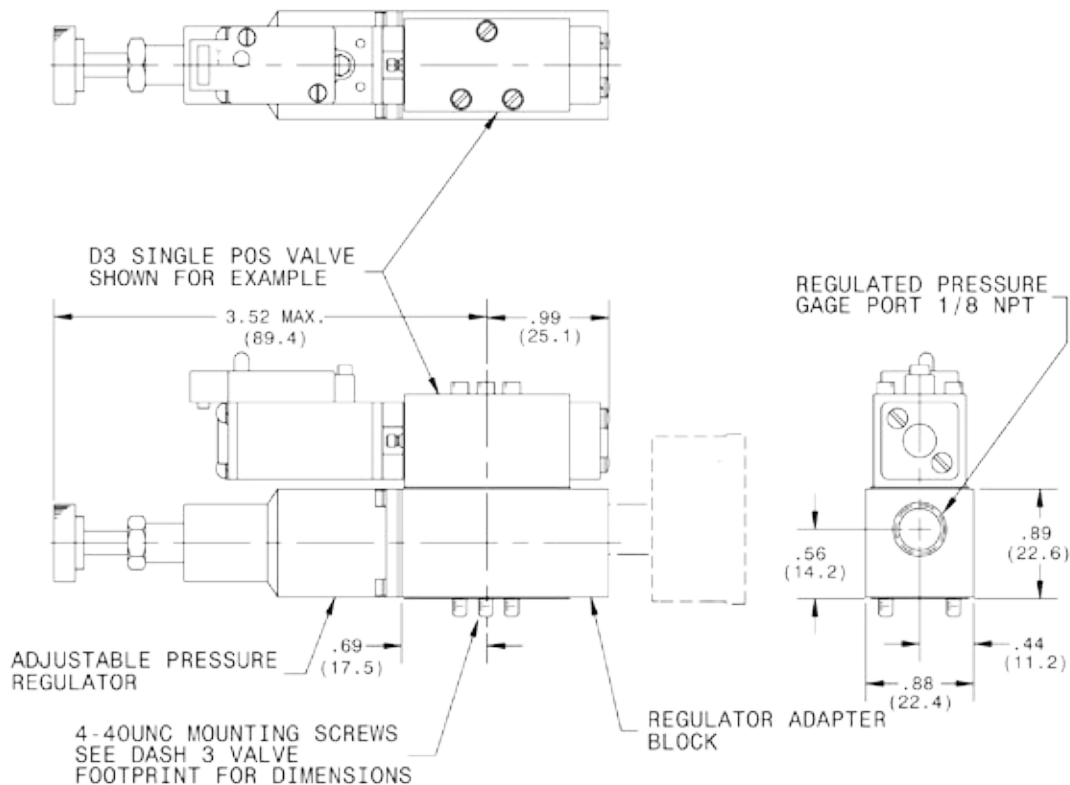

DYNAMCO

Digital Position Controller

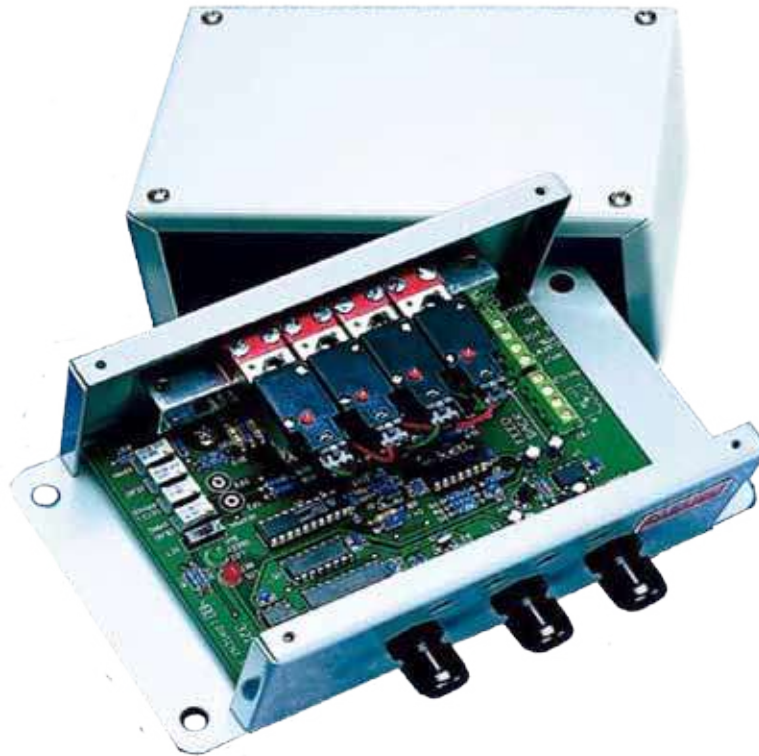

INTRODUCTION

The DYNAMCO Position Control System (Model DPC) is designed to control and provide accurate positioning of pneumatic cylinders with position feedback. The Model DPC uses pneumatic valve technology to accurately stop and hold a cylinder in any desired position mid-stroke.

The Model DPC is controlled by a command signal of analog voltage (0 to 10 V) to move to and hold a specific rod extension. (Note: The system can be configured to accept a 4-20 mA signal). The Model DPC compares the command signal received with the position signal it is receiving from the cylinder and uses high speed pneumatic control valves to move the cylinder to the correct position. At the command position, all valves close to trap air in both sides of the cylinder and firmly hold it in position. If the cylinder loading changes, the Model DPC will automatically adjust the loading on the cylinder to hold the command position.

COMMAND SIGNAL

The Model DPC will accept command signals from devices as simple as a voltage switch, and as complex as a PLC or large computer system.

ZERO

The Zero Adjustment allows the user to set the fully retracted (0 Volt) position anywhere in the initial 50% of the full cylinder stroke

SPAN

The Span Adjustment provides the user the ability to set the fully extended (10 volt) position anywhere in the latter 50% of the full cylinder stroke.

DEADBAND

The Deadband Adjustment allows the user to set the tolerance that the Model DPC will allow between the command signal and the cylinder's feedback signal.

DECEL RANGE

The Decel Range Adjustment allows the user to control the deceleration profile of the cylinder as it approaches its command position.

ACCURACY

Accuracy is dependant on the cylinder feedback signal and the specific performance of the cylinder. However, the Model DPC has been designed to position accurately to within +/- 0.05% of the cylinder stroke.

Digital Position Controller



MODEL CODING

EXAMPLE: DPC A N 1 E 0

ELECTRICAL CONNECTOR

- A 0.031" (0.8mm) Orifice (Black DASH 1)
- B 0.063" (1.6mm) Orifice (Red DASH 1)
- C 0.089" (2.3mm) Orifice (Silver DASH 1)
- D DASH 3 Flow 1
- E DASH 3 Flow 2
- F DASH 3 Flow 3
- G DASH 3 Flow 4
- H DASH 3 Flow 5

DIN CONNECTOR

- K 0.031" (0.8mm) Orifice (Black DASH 1)
- L 0.063" (1.6mm) Orifice (Red DASH 1)
- M 0.089" (2.3mm) Orifice (Silver DASH 1)
- N DASH 3 Flow 1
- O DASH 3 Flow 2
- P DASH 3 Flow 3
- Q DASH 3 Flow 4
- R DASH 3 Flow 5

UNASSIGNED

PACKAGING

- E Standard Enclosure (for wires)
- C Standard Enclosure (with connectors)

ELECTRONICS

- 1 0-10 V (DASH 1)
- 2 4-20 mA (DASH 1)
- 3 0-10 V (DASH 3)
- 4 4-20 mA (DASH 3)

PORT THREADS

- N NPT
- B BSPP

DIMENSIONS

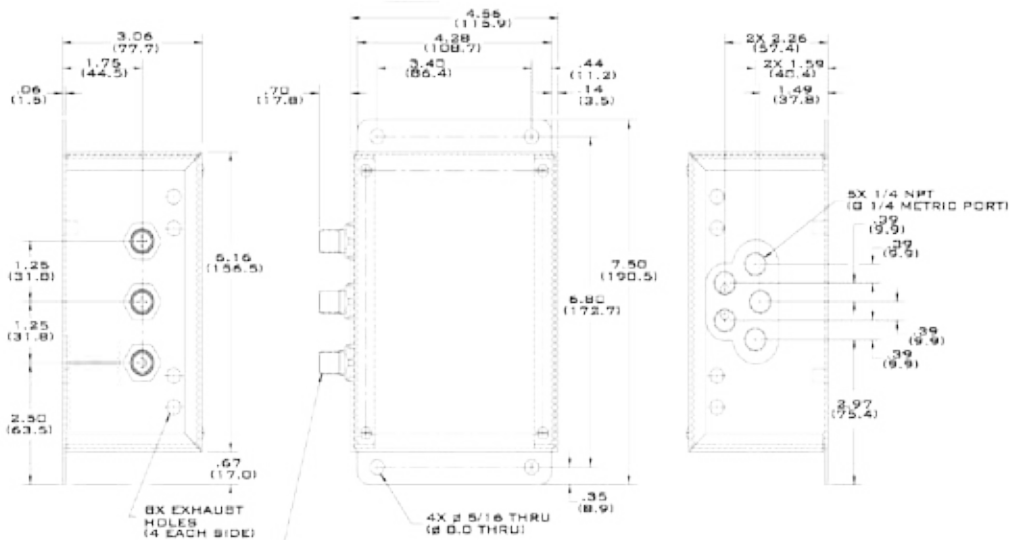

SPECIFICATIONS

Air Pressure..... 70-80 psi (4.8-5.5 bar)

Filtration..... 20 micron

NOTE: It is important that connections are leak free. Leakage of any kind will cause the DPC to constantly adjust for the pressure loss, which will create unnecessary wear on the valves and generate small noises.



Additional Information

EXPLANATION OF DYNAMCO DATE-OF-MANUFACTURE CODES

At the time our product passes its final test, our product label will be attached prior to shipment. The label will contain the model number of the product and a two letter code to indicate the month and year of manufacture.

The code will consist of two letters placed on the extreme right side of the label. The first letter represents the month while the second letter represents the year.

Month.....	Code Letter
January.....	A
February.....	B
March.....	C
April.....	D
May.....	E
June.....	F
July.....	G
August.....	H
September.....	I
October.....	J
November.....	K
December.....	L

Year.....	Code Letter
1997.....	A
1998.....	B
1999.....	C
2000.....	D
2001.....	E
2002.....	F
2003.....	G
2004.....	H
2005.....	I
2006.....	J
2007.....	K
2008.....	L
2009.....	M
2010.....	N
2011.....	O
2012.....	P
2013.....	Q
2014.....	R
2015.....	S
2016.....	T
2017.....	U
2018.....	V
2019.....	W
2020.....	X
2021.....	Y
2022.....	Z



This valve was manufactured in May 2008.

OTHER PRODUCTS

In addition to solenoid valves, DYNAMCO offers other products, including Two Hand Non-Tie-Down Controls, Air Logic components, and a full line of Pneumatic Fittings. For more information on these products, please contact DYNAMCO or your authorized DYNAMCO representative.



Fittings



	211-1 TUBE ID x THREAD .063 x 10-32		1291-1 THREAD x THREAD 10-32 x 10-32 (M5 x M5)		209-1 TUBE ID .063
	211-9 TUBE ID x THREAD .094 x 10-32 (2.5 x M5)		1292-1 TUBE ID x THREAD .063 x 10-32		1047-1 THREAD 10-32
	211-2 TUBE ID x THREAD .125 x 10-32 (4.0 x M5)		1293-1 TUBE ID x THREAD .125 x 10-32 (4.0 x M5)		1241-1 TUBE ID .063
	468-2 PLUG 10-32 (M5)		1294-1 THREAD 10-32		1298-1 THREAD 10-32
	380-2 CAP FOR .063 BARB		1295-1 TUBE ID x THREAD .063 x 10-32		507-1 CAP 1/8 NPT
	1046-1 THREAD x THREAD 10-32 x 10-32		1296-1 TUBE ID x THREAD .125 x 10-32 (4.0 x M5)		399-2 BULKHEAD 10-32 x 1/8 NPT
	391-2 TUBE ID x TUBE ID .063 x .063		524-2 TUBE ID x THREAD .063 x 1/8 NPT	POLYURETHANE TUBING	
	520-1 TUBE ID x TUBE ID .125 x .125 (4.0 x 4.0)		528-1 THREAD x THREAD 10-32 x 1/8 NPT	Size .063 ID x .125 OD	
	210-1 TUBE ID x THREAD .063 x 1/8 NPT		526-1 TUBE ID x THREAD .063 x 1/8 NPT	Color	Part Number
	521-1 TUBE ID x THREAD .125 x 1/8 NPT		PLUG 506-5 1/8 NPT 506-6 1/4 NPT	Clear	150-3
	210-2 TUBE ID x THREAD .063 x 1/8 NPT		510-1 REDUCER 1/4 - 1/8 NPT	Black	148-0
				Size .125 ID x .250 OD	
				Color	Part Number
				Clear	150-4
				Black	149-0

NOTE: For more information on our fittings, please refer to our fittings catalog.





Customized Products



Can't find what you're looking for? Don't worry. At DYNAMCO, we have made thousands of specialized products to give our customers exactly what they are looking for at prices that are very affordable, even for small quantities. Our engineers are ready to assist you in building something that works for you, and usually we can assemble a working prototype in 5 days or less.

Call us today, or email us at sales@dynamco.com to get started.



Atec-Cyl SA
Rte de l'Orée-du-Bois 3
2300 La Chaux-de-Fonds
Switzerland

info@atec-cyl.ch
www.atec-cyl.ch
+41 (0)32 924 06 06

DYNAMCO
A Division of Roper Pump Company
P.O. Box 269
Commerce, GA 30529 USA
TEL: (706) 336-3430
FAX: (706) 335-5490
www.dynamco.com
sales@dynamco.com

Your Authorized DYNAMCO Representative